

Name: Kenji Osaka
Date: 2001/3/3
Track: O.S Field Track

Track Size: Open Med. Tight
Conditions Traction: High Med. Low
 Surface: Smooth Bumpy

Front Suspension

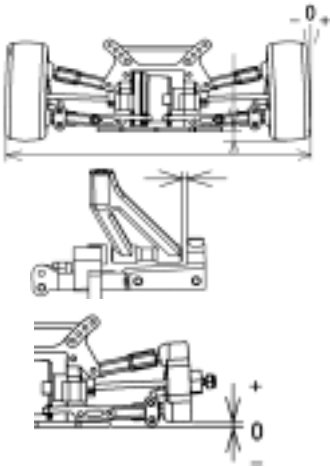

Track width 198 mm
 Ride height 4 mm
 Camber angle -1.5 °
 Caster angle 2 mm
 Toe angle 1.5 out °
 Rebound stop 2 mm
 Bump stop None Use _____ mm

Front shocks



Piston 1.1X1
 Oil # 600
 Spring Gray
 Tension _____ mm

Shock position

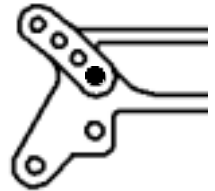

Front diff. Oil # 10000

Rear suspension

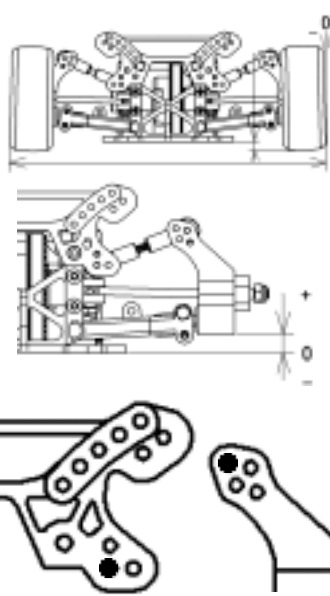

Track width 199 mm
 Ride height 5 mm
 Camber angle -3 °
 Toe angle 2 IN °
 Rebound stop 8 mm
 Bump stop None Use _____ mm

Rear shocks



Piston 1.1X2
 Oil # 600
 Spring Gray
 Tension _____ mm

Shock position



Rear diff. Oil # 30000

Upper arm position
 Anti-roll bar None Use 2 mm

Clutch

3 P Clutch shoes Black White
 Spring _____
 Other Clutch shoes Black
 Spring Silver
 Clutch bell clearance 0.4 mm
 Clutch spring adj. Nut 0.5 mm

Gear ratio 1st 16/49
 2nd 20/43

Brake pad Black Yellow

Engine

Type MT12 Fuel Bylon 30
 Gasket 0.3 mm Muffler Nova 50221
 Plug C6TC

Tires & Wheels

Front Tire FVX4-D (37) **Rear** Tire FVX5-D (37)
 Insert _____ Insert _____
 Wheel FAST Wheel FAST

Body & Wing

Body Dodge (Protoform) Wing Normal

Result

Race time / Lap _____
 Best lap (1Lap) 17'3

Comments: Use Front Stabilizer ⊖
 Adjust the F/R Spring Tension with Ride Height

