

Name: Keisuke Fukuda
Date: 10/30/05
Track: SPL2

Track conditions

Size: Open Med. Tight
 Traction: High Med. Low
 Surface: Smooth Med. Bumpy

Front suspension

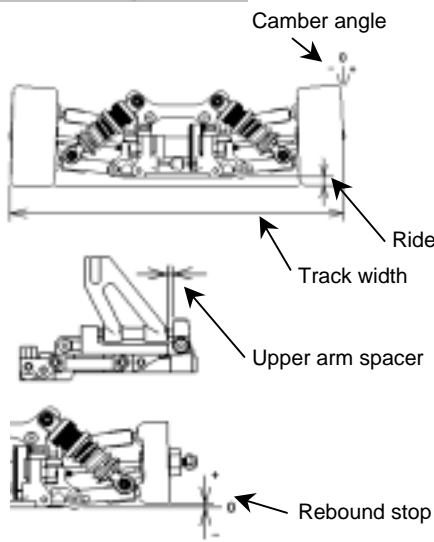

Track width 199 mm
 Ride height 4.5 mm
 Camber angle 2 °
 Upper arm spacer 2 mm
 Toe angle out 2 °
 Rebound stop 1 mm
 Bump stop None Use
 Upper arm position 2 mm
 Anti-roll bar

Front shock

Piston 1.3x1
 Oil # 400
 Spring Purple
 Sock position

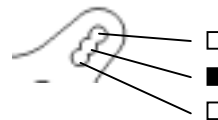

Front Diff.

One way
 Gear diff. Oil # _____
 Rigid

Steering ackerman

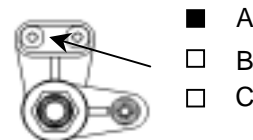

Rear suspension

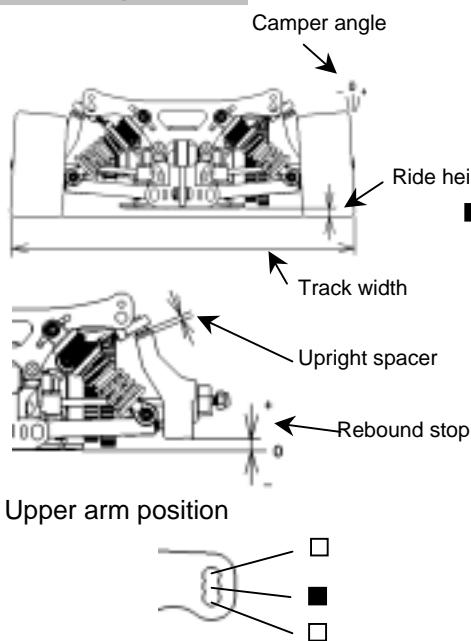

Track width 200 mm
 Ride height 5.5 mm
 Camber angle 3.5 °
 Toe angle in 1.5 °
 Rebound stop 5 mm
 Bump stop None Use
 Lower arm position
 Upright spacer 2 mm
 Anti-roll bar Wire ϕ 2.1
 Other 2 mm

Rear Shock

Piston 1.1x2
 Oil # 400
 Spring Purple
 Shock position

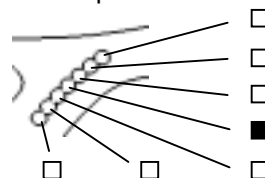

Rear Diff.

Oil # 30,000

Engine Type Novarossi N12LL3
 Gasket 0.3 mm Muffler ZAC
 Plug 7Tf Fuel Cosmo

Tire <Front> Type Kawahara37BA <Rear> Type Kawahara37BA
 Dia.(start) L 62 /R 62 Dia.(start) L 64.5 /R 64.5
 Dia.(finish) L /R Dia.(finish) L /R

Clutch

Clutch shoe Black Gray Red
 Centrifugal shoe Light (2pcs.)
 Spring Hard
 Clutch bell clearance 0.4 mm
 Spring adj. Nut position 0.5 mm

Brake pad

Black Other

Body

Type Kawahara Accord
 Wing _____

Drive ratio

Gear ratio Side pulley
 1st. 17/60 24T
 2nd. 23/54 Other

Result

Race time / Lap _____
 Best lap (1Lap) _____

Comments:

SPL2 : <http://www.flag-1.com/image/4-1.jpg>