

Name: Kenji Osaka
Date: 4/22/2001
Track: SS Hobby Circuit

Track Size: Open Med. Tight
Conditions Traction: High Med. Low
 Surface: Smooth Med. Bumpy

Front suspension

Camber angle -2.5 °
 Upper arm position 2 mm
 Toe angle 1.5 out °
 Rebound stop 30 mm
 Bump stop
 None Use
 Anti-roll bar
 None Use 2.5 mm

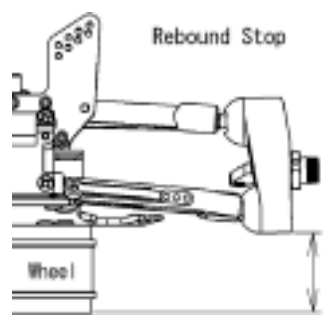
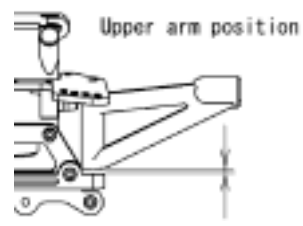

Shocks

Piston 1.4X2
 Oil # 350
 Spring Silver
 Spacer 4 mm

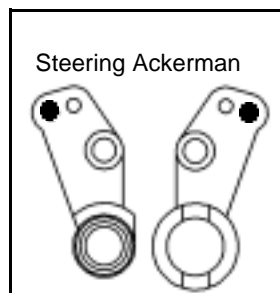
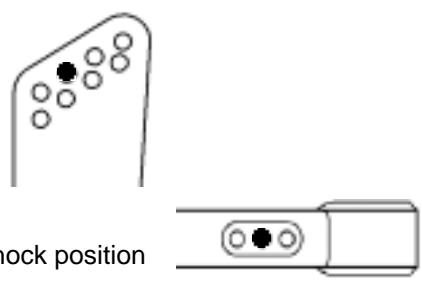

Rear suspension

Camber angle -3.5 °
 Toe angle A 0.4 mm
 B 0.8 mm
 Rebound stop 27 mm
 Bump stop
 None Use
 Anti-roll bar
 None Use 2.8 mm

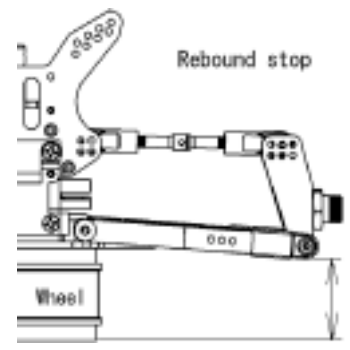
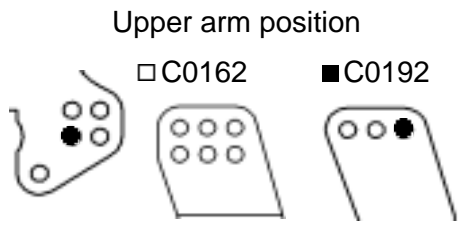
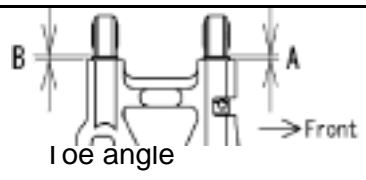

Shocks

Piston 1.4X2
 Oil # 350
 Spring Silver
 Spacer 8 mm

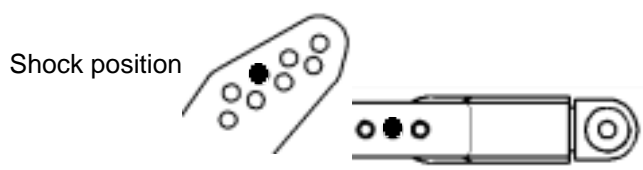

Engine Type NOVA BX21SBK (5-3)
 Gasket 0.6 mm Muffler 9853 Polish
 Plug C6G Fuel Bylon 3000

Diff. Oil Front # Torsen
 Center # 3000
 Rear # 1000

Tires **Front** Type Crime Fighter M2 Insert Mugen L
Rear Type Crime Fighter M2 Insert Mugen L

Clutch Clutch shoes Black White
 Spring 0.9 mm
 Clutch bell 13-44 T

Result
 Race time / Lap _____
 Best lap (1Lap) 35'5

Comments:
Rear Sus. Mount 3°
w/o. Front Tension Rod
Rear Diff. w/o. O-Ring