

Name: Kenji Osaka
Date: 1/7/2001
Track: JOCC Numazu

Track Size: Open Med. Tight
Conditions Traction: High Med. Low
 Surface: Smooth Med. Bumpy

Front suspension

Camber angle -2 °
 Upper arm position 0 mm
 Toe angle 1 out °
 Rebound stop 30 mm
 Bump stop
 None Use
 Anti-roll bar
 None Use 2.3 mm

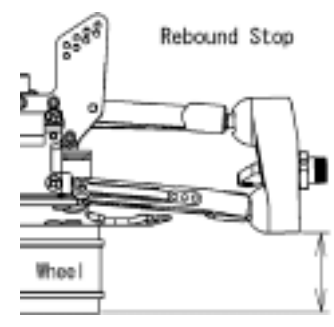
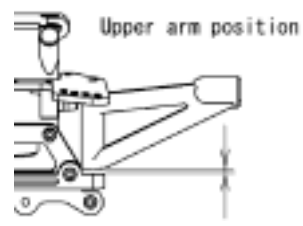

Shocks

Piston 1.4X2
 Oil # 350
 Spring Silver
 Spacer 3 mm

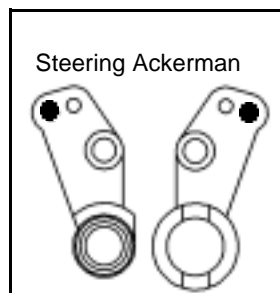
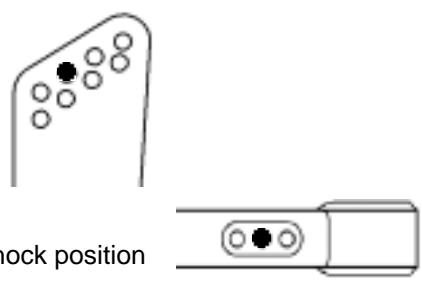

Rear suspension

Camber angle -3 °
 Toe angle A 1.2 mm
 B 1.6 mm
 Rebound stop 26 mm
 Bump stop
 None Use
 Anti-roll bar
 None Use 2.8 mm

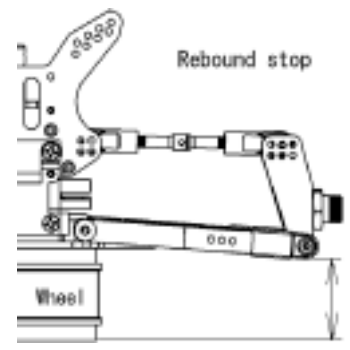
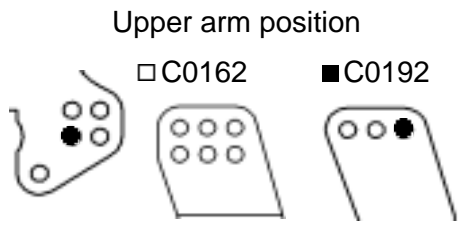
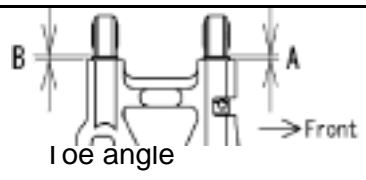

Shocks

Piston 1.4X2
 Oil # 300
 Spring Silver
 Spacer 3 mm

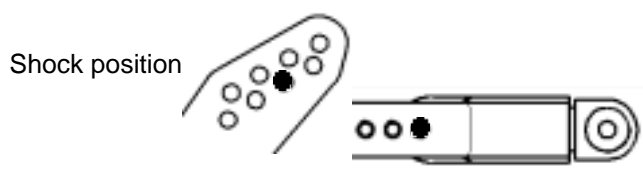

Engine Type NOVA BX21SBK
 Gasket _____ mm Muffler NOVA 053 Polish
 Plug C5S Fuel Bylon 3000

Diff. Oil Front # 5000
 Center # 7000
 Rear # 1000

Tires **Front** Type Crime Fighter M2 Insert Mugen S
Rear Type Crime Fighter M2 Insert Mugen S

Clutch Clutch shoes Black White
 Spring 1.0 mm
 Clutch bell 13 T

Result
 Race time / Lap _____
 Best lap (1Lap) _____

Comments:
 Center: 46T
 Rear: 40T