

Name : _____
Date : _____
Track : _____

Track Size: Open Med. Tight
Conditions Traction: High Med. Low
 Surface: Smooth Med. Bumpy

Front suspension

Camber angle _____ °
 Upper arm position _____ mm
 Toe angle _____ °
 Rebound stop _____ mm
 Bump stop
 None Use
 Anti-roll bar
 None Use _____ mm

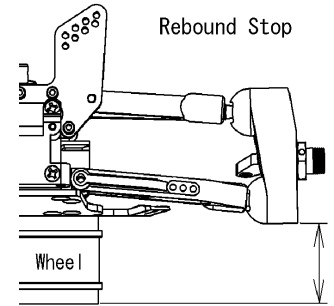
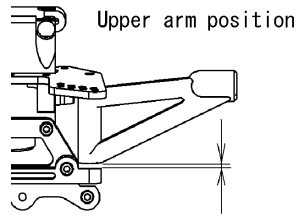

Shocks

Piston _____
 Oil # _____
 Spring _____
 Spacer _____ mm

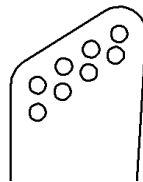

Shock position

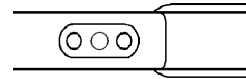

Steering Ackerman

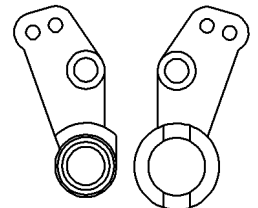

Rear suspension

Camber angle _____ °
 Toe angle A _____ mm
 B _____ mm
 Rebound stop _____ mm
 Bump stop
 None Use
 Anti-roll bar
 None Use _____ mm

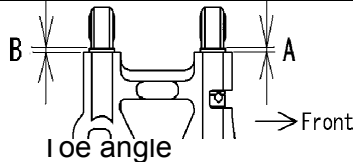

Upper arm position

C0162 C0192

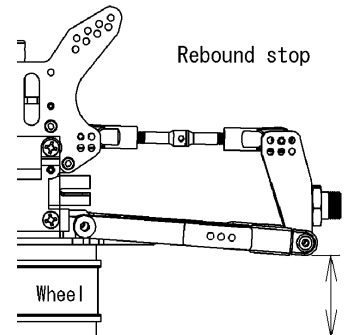
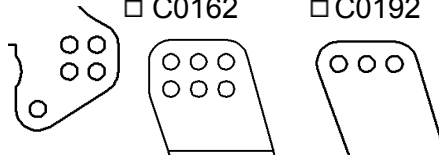

Shocks

Piston _____
 Oil # _____
 Spring _____
 Spacer _____ mm

Shock position

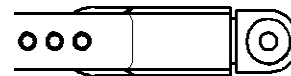
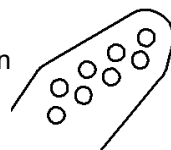

Wing Position

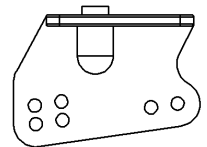

Engine Type _____
 Gasket _____ mm Muffler _____
 Plug _____ Fuel _____

Diff. Oil Front # _____
 Center # _____
 Rear # _____

Tires **Front** Type _____
 Insert _____
Rear Type _____
 Insert _____

Clutch Clutch shoes Black White
 Spring _____ mm
 Clutch bell _____ T

Result

Race time / Lap _____
 Best lap (1Lap) _____

Comments :

.....

