

Name : Kenji Osaka
Date : 4/23/2000
Track : SS Hobby Circuit

Track Size: Open Med. Tight
Conditions Traction: High Med. Low
 Surface: Smooth Med. Bumpy

Front suspension

Camber angle -2.5 °
 Upper arm position 2 mm
 Toe angle out 1 °
 Rebound stop 29 mm

Bump stop
 None Use
 Anti-roll bar
 None Use 2.3 mm

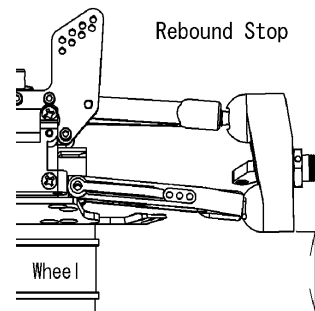
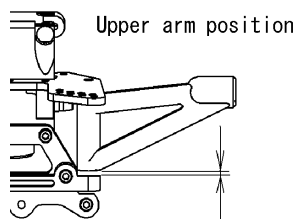

Shocks

Piston 1.3X2
 Oil # 300
 Spring Silver
 Spacer 5 mm

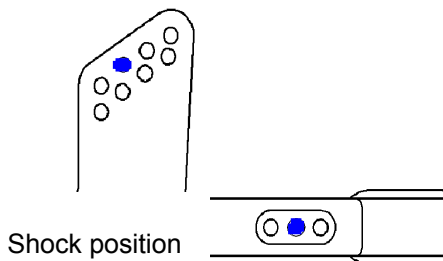

Rear suspension

Camber angle -3.5 °
 Toe angle A 1.6 mm
 B 1.6 mm
 Rebound stop 27 mm

Bump stop
 None Use
 Anti-roll bar
 None Use 2.8 mm

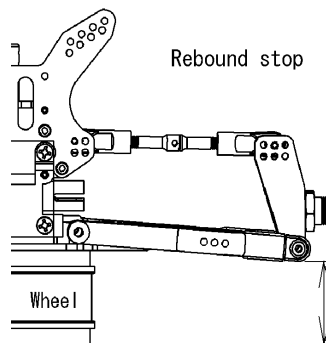
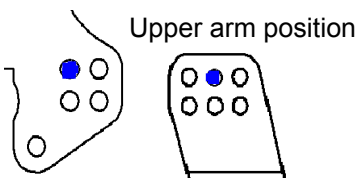
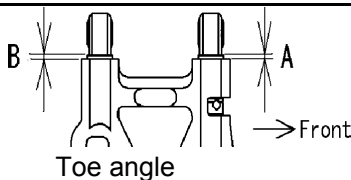

Shock

Piston 1.3X2
 Oil # 300
 Spring Silver
 Spacer 6 mm

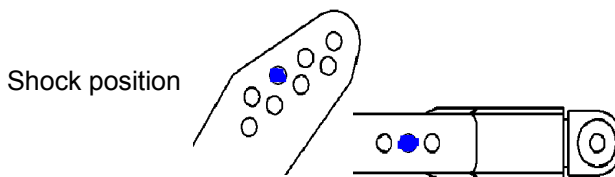

Engine Type RZ-B
 Gasket _____ mm Muffler Custom
 Plug C6G Fuel Bylon

Diff. Oil Front # 3000
 Center # 5000
 Rear # 1000 (w/o. O-Ring)

Tires **Front** Type MICRO XX Insert Mugen S X 2
Rear Type MICRO XX Insert Mugen S X 2

Clutch Clutch shoes Black White
 Spring 0.9 mm
 Clutch bell 13 T

Result
 Race time / Lap _____
 Best lap (1Lap) _____

Comments

