

Name : Kenji Osaka
Date : 4/9/2000
Track : SBRT

Track Size: Open Med. Tight
Conditions Traction: High Med. Low
 Surface: Smooth Med. Bumpy

Front suspension

Camber angle -2 °
 Upper arm position 4 mm
 Toe angle out 2 °
 Rebound stop 30 mm

Bump stop
 None Use
 Anti-roll bar
 None Use 2.1 mm

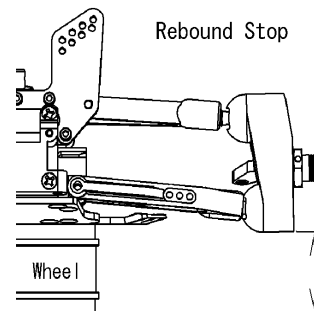
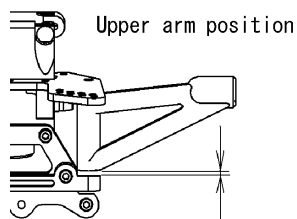

Shocks

Piston 1.4X2
 Oil # 400
 Spring Silver
 Spacer 4 mm

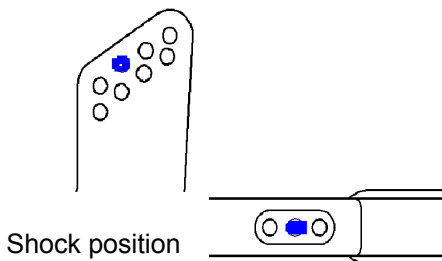

Rear suspension

Camber angle -3 °
 Toe angle A 2 mm
 B 2 mm
 Rebound stop 25 mm

Bump stop
 None Use
 Anti-roll bar
 None Use 2.6 mm

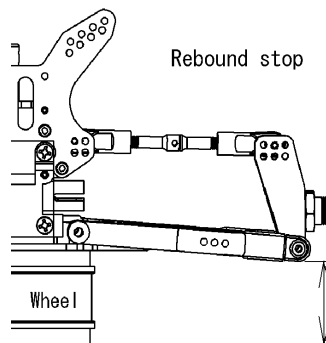
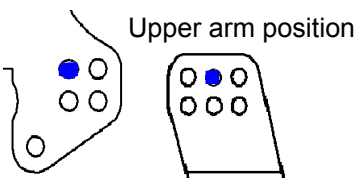
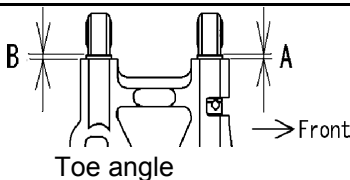

Shock

Piston 1.4X2
 Oil # 400
 Spring Silver
 Spacer 5 mm

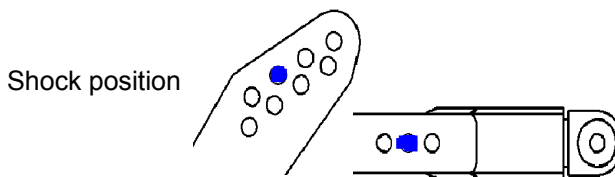

Engine Type NOVA BX21 BK
 Gasket 0.6 mm Muffler NOVA 053
 Plug C6S Fuel Cosmo 30%

Diff. Oil Front # 3000
 Center # 5000
 Rear # 1000 (w/o.O-Ring)

Tires **Front** Type PROLINE M2 Insert Mugen S
Rear Type PROLINE M2 Insert Mugen S

Clutch Clutch shoes Black White
 Spring 0.9 mm
 Clutch bell 13 T

Result
 Race time / Lap _____
 Best lap (1Lap) _____

Comments Truck View : <http://www3.plala.or.jp/custom/sbrt.htm>

