

MBX-4RR Set Up Sheet

Ver.0002



Name : Kenji Osaka
Date : 7/21/2000
Track : Kawasemi Jr.

Track Size: Open Med. Tight
Conditions Traction: High Med. Low
 Surface: Smooth Med. Bumpy

Front suspension

Camber angle -2.5 °
 Upper arm position 0 mm
 Toe angle 1.5out °
 Rebound stop 30 mm

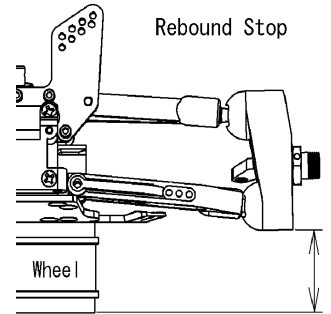
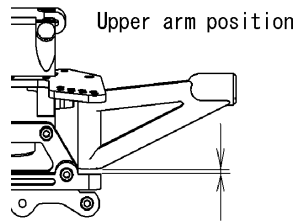

Bump stop
 None Use
 Anti-roll bar
 None Use ϕ 2.1 mm

Shocks

Piston 1.8x1
 Oil # 600
 Spring Silver
 Spacer 4 mm

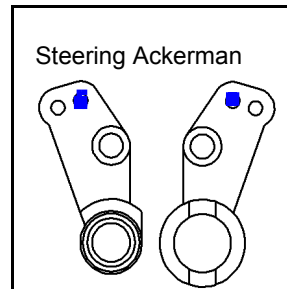
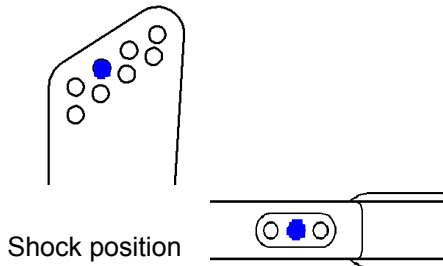

Rear suspension

Camber angle -3.5 °
 Toe angle A 0.4 mm
 B 0.8 mm
 Rebound stop 27 mm

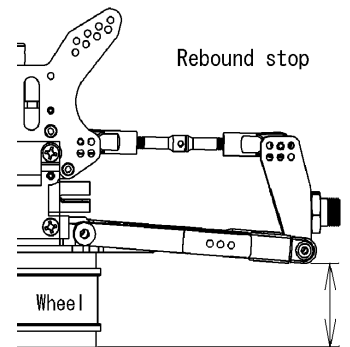
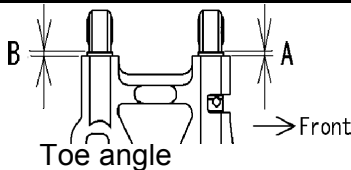

Bump stop
 None Use
 Anti-roll bar
 None Use ϕ 2.6 mm

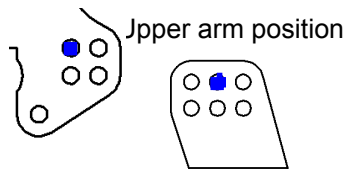

Shocks

Piston 1.8x1
 Oil # 500
 Spring Silver
 Spacer 4 mm

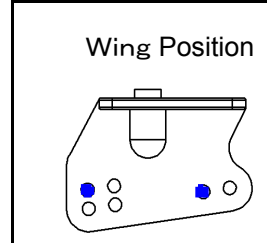
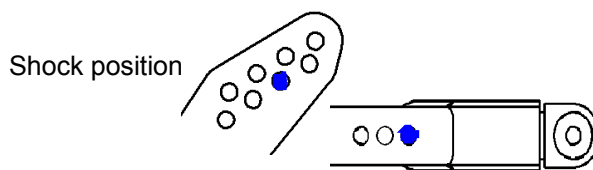

Engine Type NOVA BX21SBK
 Gasket 0.6 mm Muffler 053 Flange
 Plug C7G Fuel Byron

Diff. Oil Front # 5000
 Center # 10000
 Rear # 1000

Tires **Front** Type X SOFT
 Insert MUGEN L
Rear Type X SOFT
 Insert MUGEN L

Clutch Clutch shoes Black White
 Spring 0.9 mm
 Clutch bell 13 T

Result
 Race time / Lap _____
 Best lap (1Lap) _____

Comments Other tires: _____
 Pro Line Multi Spike M2 and Crime FighterM2
 Track Info: _____
<http://www.s-kawasemi.com/rc/>
 2000 JMRCA 1/8 Off-Road Japan Championship: Aug 24-27