

Name: Mike Swauger
Date: 2/14/2004
Track: Ft. Myers R/C Raceway

Track Conditions

Size: Open Med. Tight
 Traction: High Med. Low
 Surface: Smooth Med. Bumpy

Front suspension

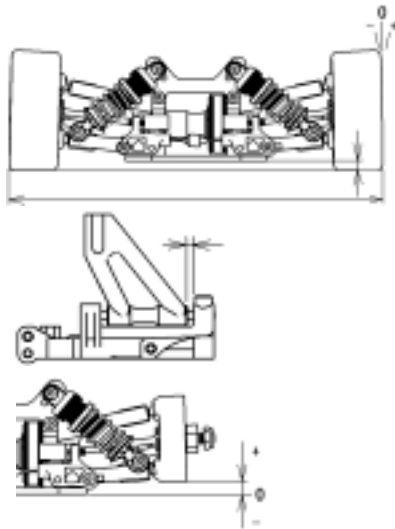

Track width 199 mm
 Ride height 4 mm
 Camber angle -2 °
 Caster angle 1 mm
 Toe angle out 0.5 °
 Rebound stop 1 mm
 Bump stop
 None Use

Anti-roll bar

Steering Ackerman (T0304)

A B C

Front shocks

Piston Stock
 Oil # 600
 Spring Blue

Shock position

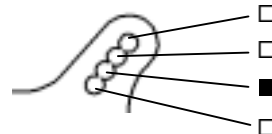

Front diff.

Gear diff.
 Oil # _____
 One way

Rear suspension

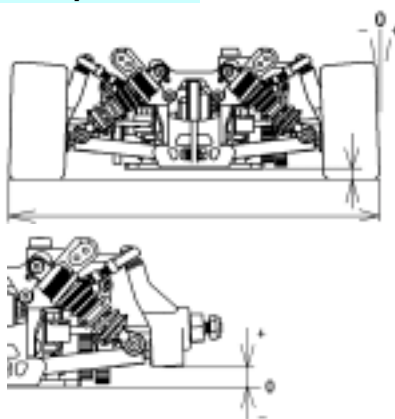

Track width 200 mm
 Ride height 5 mm
 Camber angle -4 °
 Toe angle 2 °
 Rebound stop 5 mm
 Bump stop
 None Use

Lower arm position(T0128,T0129)

4mm(A-A) 5mm(B-B) 6mm(C-C)

Anti-roll bar Kawahara mm

Upper arm position

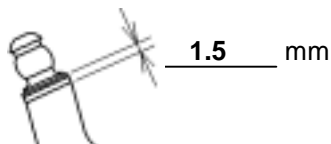
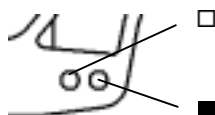

Rear shocks

Piston Stock
 Oil # 600
 Spring Blue

Shock position

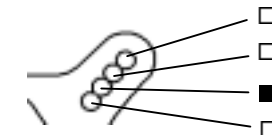

Rear diff.

Oil # 50000

Engine

Type X-12 JP
 Gasket _____ mm Muffler Mugen EFRA 2501
 Plug 6Tf Fuel Mugen Seiki Racing Fuel

Clutch

Clutch shoes Black Gray
 Centrifugal shoe Light weight
 Spring Silver

Tire

Front	Rear
Type <u>Kawahara 40°</u>	Type <u>Kawahara 42°</u>
Dia.(start) <u>L /R</u>	Dia.(start) <u>L /R</u>
Dia.(finish) <u>L /R</u>	Dia.(finish) <u>L /R</u>

Clutch bell clearance 0.4 mm
 Spring Adj. Nut position _____ mm

Body

Type Team Losi Alpha
 Wing _____

Drive ratio

1st 21 / 59
 2nd 27 / 53

Brake pad

Black Yellow

Result

Race time / Lap _____
 Best lap (1Lap) _____

Comments:

.....

