

Name: Kenji Osaka
Date: 2/15/2003
Track: Ft. Myers R/C Raceway

Track Conditions

Size: Open Med. Tight
Traction: High Med. Low
Surface: Smooth Med. Bumpy

Front suspension

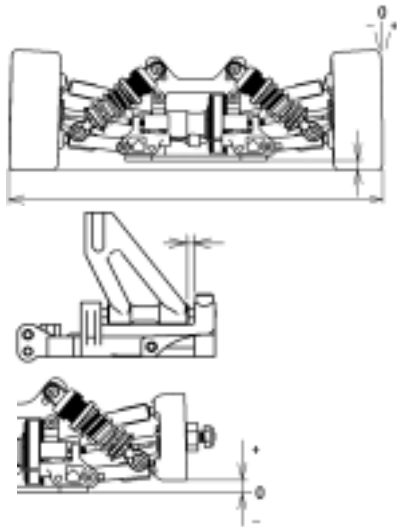

Track width 199 mm
Ride height 4.5 mm
Camber angle -2 °
Caster angle 2 mm
Toe angle out 1 °
Rebound stop 1 mm
Bump stop
 None Use

Anti-roll bar

Steering Ackerman (T0304)

A B C

Front shocks

Piston 1.1x1
Oil # 600
Spring Light Blue

Shock position

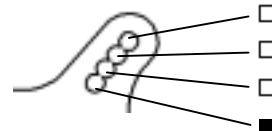

Front diff.

Gear diff.
Oil # _____
 One way

Rear suspension

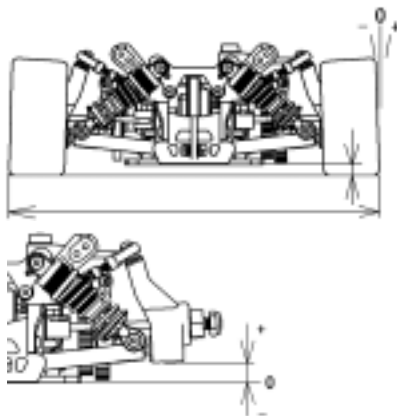

Track width 200 mm
Ride height 5.5 mm
Camber angle -3 °
Toe angle in 1.5 °
Rebound stop 5 mm
Bump stop
 None Use
Lower arm position(T0128,T0129)
 4mm(A-A) 5mm(B-B) 6mm(C-C)
Anti-roll bar 2.3 mm

Upper arm position



Rear shocks

Piston 1.1x2
Oil # 600
Spring Light Blue

Shock position

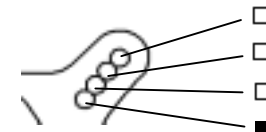

Rear diff.

Oil # 50000

Engine

Type Nova RS12
Gasket 0.3 mm Muffler Nova EFRA w/Flange φ5
Plug C7G Fuel Mugen Seiki Racing Fuel

Clutch

Clutch shoes Black Gray
Centrifugal shoe Light weight
Spring Silver

Tire

Front	Rear
Type <u>FAST FVJ4E 40°</u>	Type <u>FAST FVJ6E 40°</u>
Dia.(start) <u>L 59 /R 58.5</u>	Dia.(start) <u>L 61 /R 60.5</u>
Dia.(finish) <u>L /R</u>	Dia.(finish) <u>L /R</u>

Clutch bell clearance 0.4 mm
Spring Adj. Nut position 1.2 mm

Body

Type Protoform Dodge Stratus
Wing _____

Drive ratio

1st 16 / 47
2nd 21 / 42

Brake pad

Black Yellow

Result

Race time / Lap 23L / 5'07
Best lap (1Lap) 12'8

Comments:

Use Protoform Dodge Stratus 2.1 body for Final.