

**Name:** \_\_\_\_\_  
**Date:** \_\_\_\_\_  
**Track:** \_\_\_\_\_

**Track** Size:  Open  Med.  Tight  
**Conditions** Traction:  High  Med.  Low  
 Surface:  Smooth  Med.  Bumpy

### Front suspension

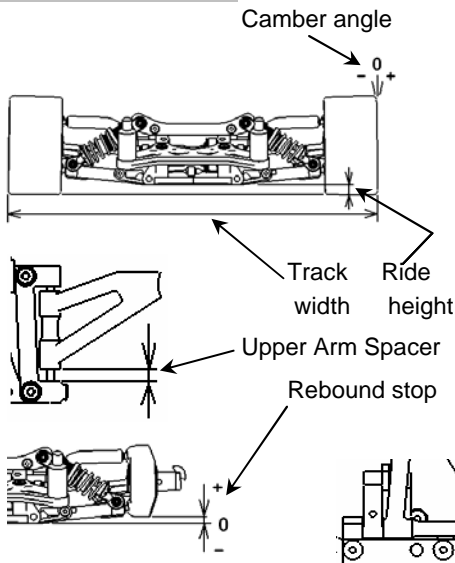

Track width 253 mm  
 Ride height 6.5 mm  
 Camber angle -2 °  
 Upper Arm Spacer 2 mm  
 Toe angle out 1.5 °  
 Rebound stop 0 mm  
 Bump stop  None  Use  
 Lower arm spacer 0 mm  
 Upper arm position 0 mm  
 Anti-roll bar

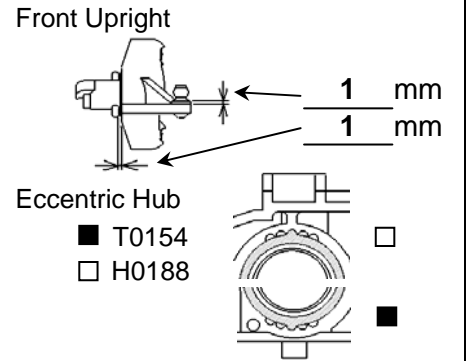

### Steering ackerman

A  
 B  
 C  
 D

### Rear suspension

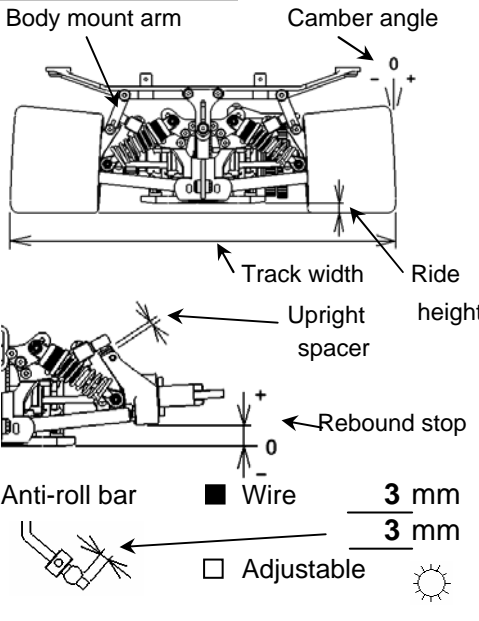

Track width 263 mm  
 Ride height 7.5 mm  
 Camber angle -3 °  
 Toe angle in 2 °  
 Rebound stop 9 mm  
 Bump stop  None  Use  
 Lower arm position(H0134)  
 4.5mm  5mm  5.5mm  
 Upright spacer 3 mm  
 Upper Arm Position  
 Eccentric Hub  
 T0154  
 H0188  
 Body mount arm  
 H0466C(Short)  
 H0466F(Long)

### Front shock

Piston Stock  
 Oil # 600  
 Springs White  
 Shock position

### Rear shock

Piston Stock  
 Oil # 600  
 Springs White  
 Shock position

**Engine** Type \_\_\_\_\_ Muffler \_\_\_\_\_  
 Gasket \_\_\_\_\_ mm Manifold \_\_\_\_\_  
 Plug \_\_\_\_\_ Fuel \_\_\_\_\_

### Clutch

Clutch shoe  Yellow  Gray  Red  
 Centrifugal shoe Light weight  
 Spring Super hard  
 Clutch bell clearance 0.4 mm  
 Spring adj. nut position 0.8 mm

**Tire** <Front> <Rear>  
 Type \_\_\_\_\_ Type \_\_\_\_\_  
 Dia.(start) L 69 /R 69 Dia.(start) L 76 /R 76  
 Dia.(finish) L /R Dia.(finish) L /R

**Brake pad**  Black  Yellow

**Body** Type \_\_\_\_\_  
 Body position \_\_\_\_\_ mm  
 Rear spoiler \_\_\_\_\_ mm

**Drive ratio** Gear ratio Side pulley  
 1st. 17/49  25T  
 2nd. 20/46  26T

### Result

Race time / Lap \_\_\_\_\_  
 Best lap (1Lap) \_\_\_\_\_

### Comments:

.....  
 .....  
 .....  
 .....