

Name: _____
Date: _____
Track: _____

Track Conditions

Size: Open Med. Tight
 Traction: High Med. Low
 Surface: Smooth Med. Bumpy

Front suspension

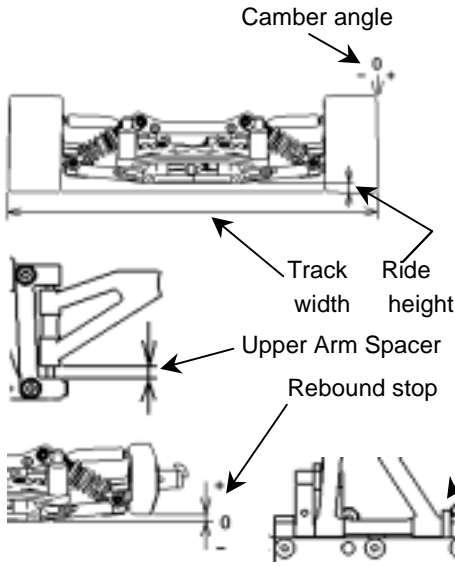

Track width 252 mm
 Ride height 5 mm
 Camber angle -1.5 °
 Upper Arm Spacer 5 mm
 Toe angle out 1 °
 Rebound stop 0 mm
 Bump stop None Use
 Lower arm spacer 3 mm
 Upper arm position 0 mm
 Anti-roll bar

Front Upright

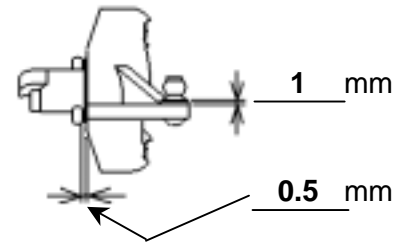

Steering ackerman

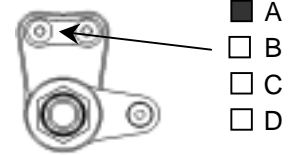

Rear suspension

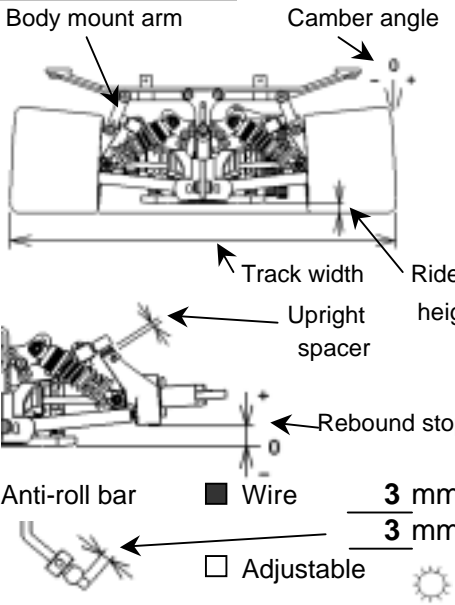

Track width 263 mm
 Ride height 6 mm
 Camber angle -3 °
 Toe angle in 1.5 °
 Rebound stop 9 mm
 Bump stop None Use
 Lower arm position(H0134) 4.5mm 5.5mm
 Upright spacer 2 mm
 Upper Arm Position
 Body mount arm Long(H0466C) Short(H0466D)
 Anti-roll bar Wire 3 mm Adjustable 3 mm

Front shock

Piston Stock
 Oil # 600
 Springs White
 Shock position

Rear shock

Piston Stock
 Oil # 600
 Springs White
 Shock position

Engine Type _____ Muffler _____
 Gasket _____ mm Manifold _____
 Plug _____ Fuel _____

Clutch

Clutch shoe Yellow Gray Red
 Centrifugal shoe Light weight
 Spring Super hard
 Clutch bell clearance 0.4 mm
 Spring adj. nut position 0.8 mm

Tire <Front> Type _____ <Rear> Type _____
 Dia.(start) L 69 /R 69 Dia.(start) L 76 /R 76
 Dia.(finish) L /R Dia.(finish) L /R

Brake pad

Black Yellow

Body Type PROTOform LOLA T530
 Body position 10 mm
 Rear spoiler 5 mm

Drive ratio

Gear ratio Side pulley
 1st. 17/49 25T
 2nd. 20/46 26T

Result

Race time / Lap _____
 Best lap (1Lap) _____

Comments:

.....

