

**Name:** Kenji Osaka  
**Date:** 6/29/03  
**Track:** Madarao Kogen RC Park

### Track Conditions

Size:  Open  Med.  Tight  
 Traction:  High  Med.  Low  
 Surface:  Smooth  Med.  Bumpy

### Front Suspension

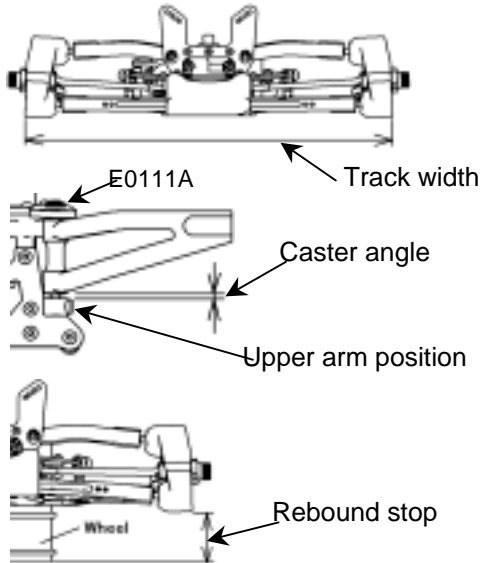

Track width 276 mm  
 Camber angle -2 °  
 Caster angle 2 mm  
 Toe angle -1 °  
 Rebound stop 21 mm  
 Anti-roll bar  Use 2.3 mm  
 None  
 Lower arm position  E0105A (-1°)  
 E0105B (-2°)  
 E0105C (-3°)  
 Upper arm position (E0111A)  
    
 E0106A - E0106B (High)  
 E0106C - E0106D (Low)

### Front Shocks

Piston 1.5x2  
 Oil # 350  
 Spring Gray  
 Spacer 2 mm  
 Shock position

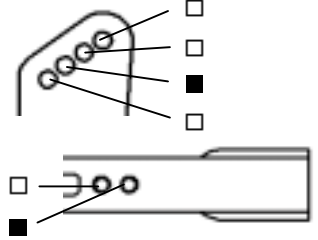

### Steering Ackerman

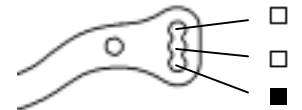

### Rear Suspension

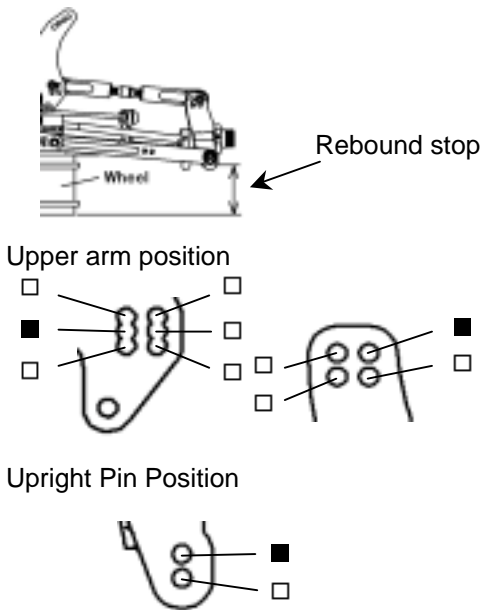

Camber angle -3 °  
 Toe angle  E0105D (2°)  
 E0105E (2.5°)  
 E0105F (3°)  
 Rebound stop 17 mm  
 Anti-roll bar  Use 2.8 mm  
 None  
 Caster angle (E0111C, E0111D)  
     
 Wheelbase adjustment  
5 mm  
 Front

### Rear Shocks

Piston 1.5x2  
 Oil # 350  
 Spring Gray  
 Spacer 5 mm  
 Shock position

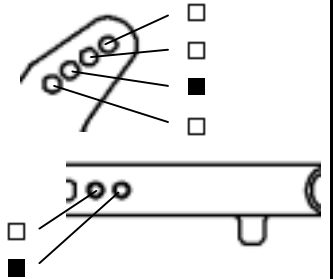

### Wing Position

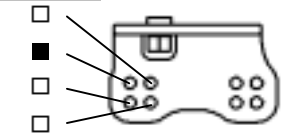

### Engine

Type Nova RX21P5TA1 JP  
 Gasket 0.7 mm Muffle 9901 Polish  
 Plug C7TGC Fuel MSRF

### Diff. Oil

Front # 3000 O-Ring 4 pcs.  Other \_\_\_\_\_  
 Center # 3000 2 pcs.  Other \_\_\_\_\_  
 Rear # 1000 - pcs.  Other \_\_\_\_\_

### Tire

**Front**  
 Type Micro XX  
 Foam S x 2

**Rear**  
 Type Micro XX  
 Foam S x 2

### Clutch

Clutch shoes  Aluminium  Other \_\_\_\_\_  
 Spring 1.0 mm  
 Clutch bell / Spur gear 13T / 44T

### Result

Race time / Lap \_\_\_\_\_  
 Best lap (1Lap) \_\_\_\_\_

### Comments:

\*\* Cut the part where the wheel of rear upper arm end hits.  
 MK RC Park: <http://www.madarao.co.jp/hotel/hplan/81b/couse.htm>  
 The total length: 333m Home straight: 50m  
 Japan Championship will be held at this track from Sep 5 to 7, 2003.