

Name: _____
Date: _____
Track: _____

Track conditions

Size: Open Med. Tight
Traction: High Med. Low
Surface: Smooth Med. Bumpy

Result

Race time / Lap: _____
Best lap (1Lap): _____

Front suspension

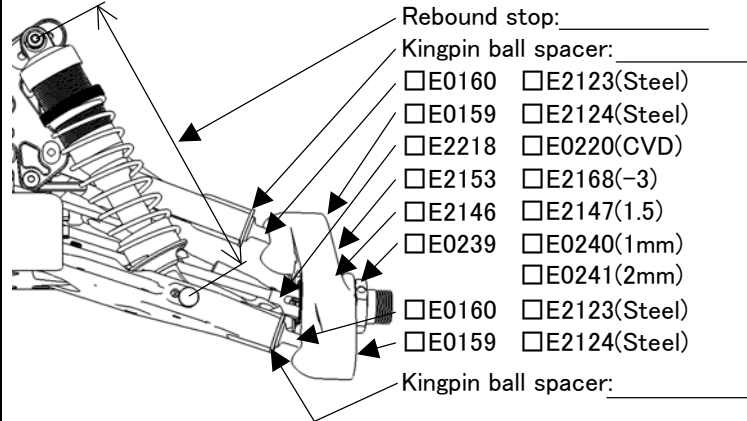

Ride height: _____
Toe angle: _____

Lower arm plate:
 E2144A,B
 E2154(CFRP 1mm)
 E2155(CFRP 1.2mm)

Anti roll bar: _____
Upper arm spacer: _____

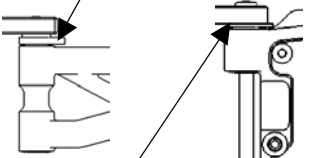

Upper arm position:

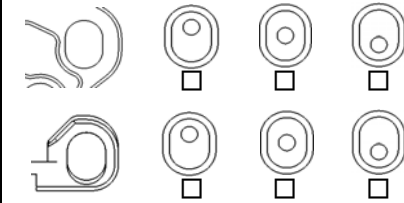

Lower arm position (Kick up):

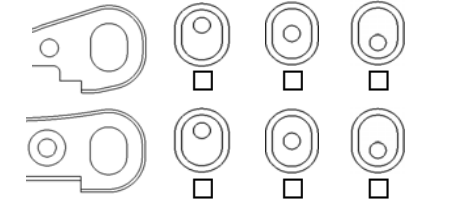

Lower arm spacer: _____

Front shocks

Piston: _____ Oil: _____
Spring: _____

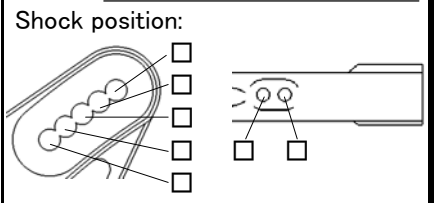

Shock position:
Pivot ball position: Front Rear
Damper stay: E2562(Aluminum)
 E2565(CFRP)

Steering ackerman

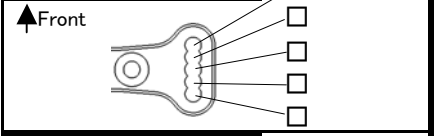

Front upper plate

E2148D E2158(CFRP)

Servo saver arm

E2301A E2310(Aluminum)

Rear suspension

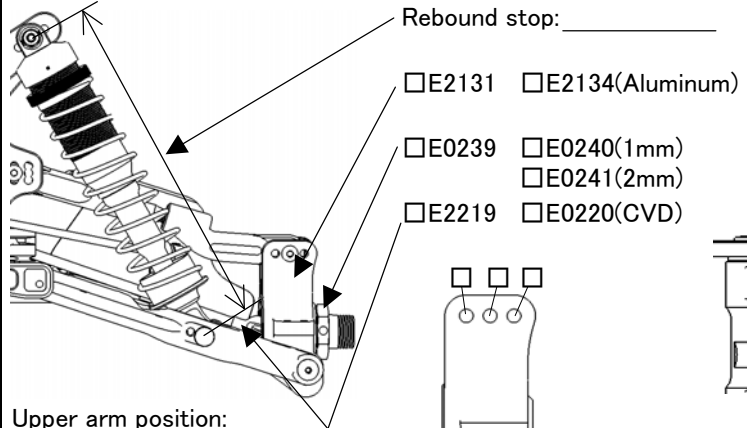

Ride height: _____

Camber angle: _____

Lower arm plate:
 E2145A,B
 E2156(CFRP 1mm)
 E2157(CFRP 1.2mm)

Anti roll bar: _____
Lower arm spacer: _____

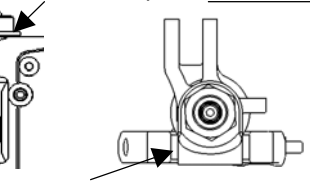

Upper arm position:

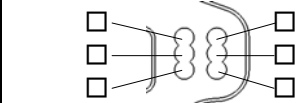

Lower arm position:

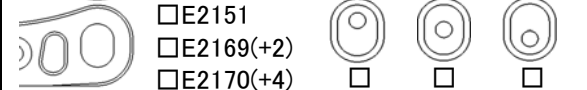

Upright spacer: _____

Lower arm position:

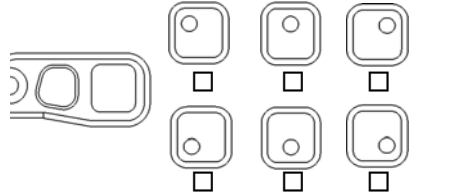

Rear shocks

Piston: _____ Oil: _____
Spring: _____

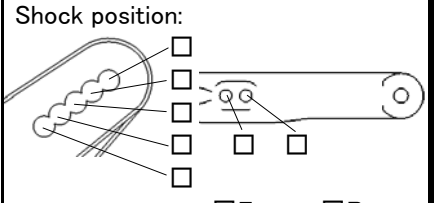

Shock position:
Pivot ball position: Front Rear
Damper stay: E2563(Aluminum)
 E2566(CFRP)

Center shaft

E2228,E2229
 E0223,E0259(CVD) E2261,E2262

Tension rod

Front: E2107A(Long) E2107B(Short)
Rear: E2148C E0803(Rubber)

Weight

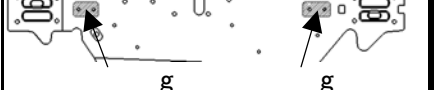

Power train

Motor: _____
ESC: _____
Battery: _____

Diff. gear

Oil _____
Front: 44/13T 42/12T
Rear: 44/13T 42/12T
Center: 44T 46T

Tires

	Front	Rear
Type:	_____	_____
Compound:	_____	_____
Inserts:	_____	_____
Wheel:	_____	_____

Pinion gear

12T 13T 14T
 15T 16T 17T
 18T

Body/Wing

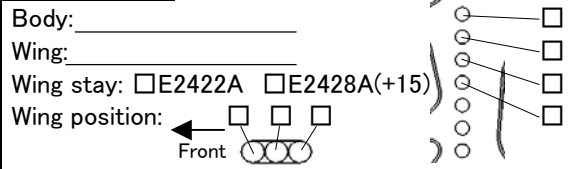

Comments

.....
.....
.....
.....
.....