

Name: Kenji Osaka
Date: Oct 15-19, 2008
Track: FEMCA 2008

Track Conditions

Size: Open Med. Tight
 Traction: High Med. Low
 Surface: Smooth Med. Bumpy

Front Suspension

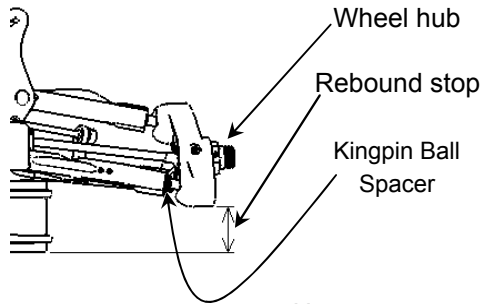

Kingpin ball spacer 1 mm
 Camber angle -2 °
 Upper arm spacer 2 mm
 Toe angle out 1 °
 Rebound stop 12 mm
 Anti-roll bar ϕ 2.3 mm
 Wheel Hub 0 mm
 Lower arm mount (Kick up)



Lower arm plate (E0154A)

Upper arm position (E0148B, E0148C)

Lower arm spacer 1 mm

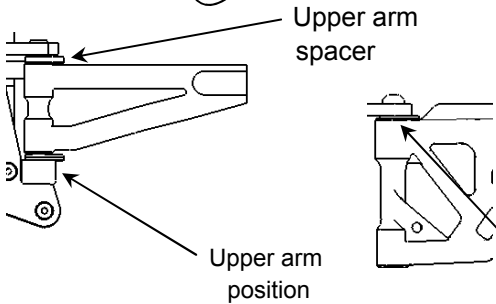

Front Shocks

Piston 1.35x5
 Oil # 400
 Spring 10.0x75
 Spring adjustmer 5.5 mm

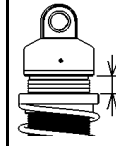

Shock position

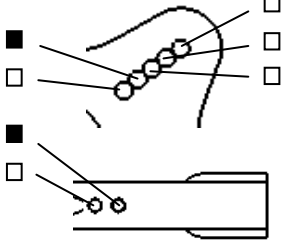

Steering Ackerman

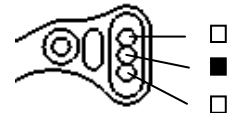

Rear Suspension

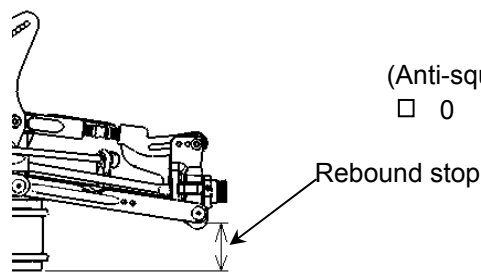

Camber angle -2.5 °
 Lower arm mount (Anti-squat) 0 1
 (Toe angle) 2.75 °
 Rebound stop 12 mm
 Anti-roll bar ϕ 2.8 mm
 Anti-squat (E0111C, E0111D)



Upright E0152
 E0173 (Aluminium)

Wheelbase adjustment

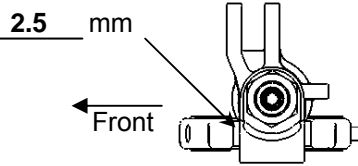

Lower arm spacer 0 mm

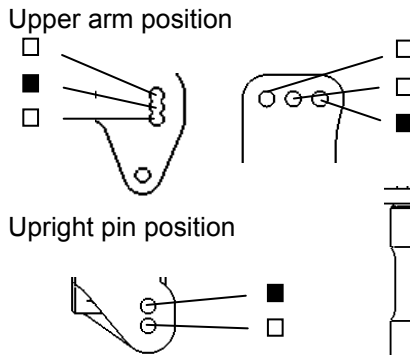

Rear Shocks

Piston 1.35x5
 Oil # 350
 Spring 10.75x86
 Spring adjustmer 9.5 mm

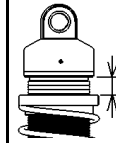

Shock position

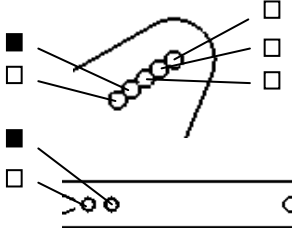

Wing Position

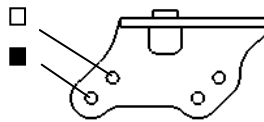

Engine	Type	Ninja JX21-B01A	
Gasket	0.3 mm	Reducer	ϕ 6.0
Plug	P4	Fuel	
Muffler	Ninja 2042		

Diff. Oil	#	O-Ring	pcs.	Other
Front	10000	0	0	<input type="checkbox"/> Other
Center	5000	0	0	<input type="checkbox"/> Other
Rear	2000	0	0	<input type="checkbox"/> Other

Tire	Front	Rear
Type	Crime Fighter XTR	Crime Fighter XTR
Foam		

Clutch	Clutch shoes	Aluminium
	0.9, 1.0, 1.0 mm	<input type="checkbox"/> Other
	Clutch bell / Spur gear	13T / 44T

Result
 Race time / Lap _____
 Best lap (1Lap) _____

Comments:
 Quality : Crime Fighter M2

