

Name: \_\_\_\_\_  
 Date: \_\_\_\_\_  
 Track: \_\_\_\_\_

### Track Conditions

Size:  Open  Med.  Tight  
 Traction:  High  Med.  Low  
 Surface:  Smooth  Med.  Bumpy

### Front Suspension

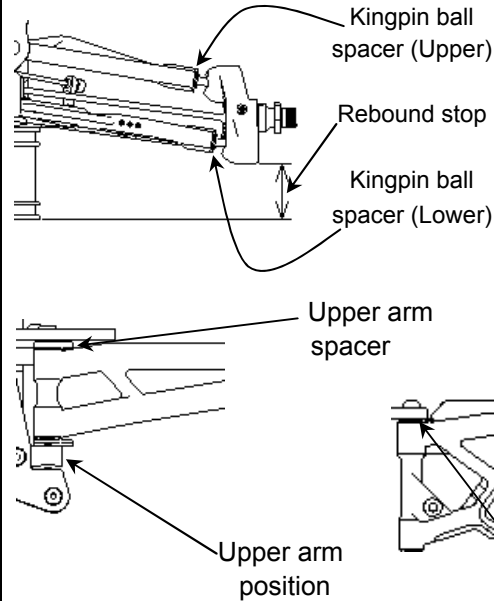

Kingpin ball spacer (Upper) 1 mm  
 Kingpin ball spacer (Lower) 1 mm  
 Upper arm spacer 2 mm  
 Toe angle out 1 °  
 Rebound stop Full mm  
 Anti-roll bar φ 2.5 mm

Lower arm mount (Kick up)  
 0  
 1  
 Lower arm plate (E0154A)  
   
   
 Upper arm position(E0148B,E0148C)  
    
 Lower arm spacer 1 mm

### Front Shocks

Piston Stock  
 Oil # 500  
 Spring L75-10  
 Spring adjustment 10 mm  
 Shock position

### Steering Ackerman

### Rear Suspension

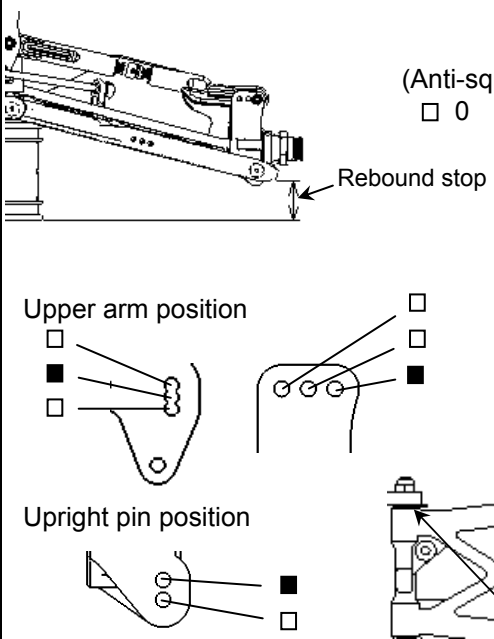

Camber angle -2 °  
 Lower arm mount (Anti-squat)  0  1  
 (Toe angle) 3 °  
 Rebound stop Front-1 mm  
 Anti-roll bar φ 2.9 mm  
 Anti-squat (E0111C,E0111D)

Upright  E0152  
 E0173(Aluminium)  
 Wheelbase adjustment 2.5 mm  
 Lower arm spacer 1 mm

### Rear Shocks

Piston Stock  
 Oil # 450  
 Spring L86-10  
 Spring adjustment 13 mm  
 Shock position

### Wing Position

**Engine** Type \_\_\_\_\_  
 Gasket \_\_\_\_\_ mm Reducer φ \_\_\_\_\_  
 Plug \_\_\_\_\_ Fuel \_\_\_\_\_  
 Muffler \_\_\_\_\_

**Diff. Oil**  
 Front # 7000 O-Ring 0 pcs.  Other \_\_\_\_\_  
 Center # 10000 0 pcs.  Other \_\_\_\_\_  
 Rear # 4000 0 pcs.  Other \_\_\_\_\_

**Tire**  
**Front** Type \_\_\_\_\_ Foam \_\_\_\_\_  
**Rear** Type \_\_\_\_\_ Foam \_\_\_\_\_

**Clutch** Clutch shoes  Aluminium Stock  
 Other \_\_\_\_\_  
 Spring 1.0 mm  
 Clutch bell / Spur gear 13T / 46T

**Result**  
 Race time / Lap \_\_\_\_\_  
 Best lap (1Lap) \_\_\_\_\_

**Comments:**  
 \_\_\_\_\_  
 \_\_\_\_\_  
 \_\_\_\_\_  
 \_\_\_\_\_