

DATE	8/24/2017
DRIVER	Atsushi Hara
TRACK	RC Adviser Champ

CARPET  ASPHALT

### TRACTION

LOW  MEDIUM  HIGH

### LAYOUT

SLOW  MIXED  FAST

### ELECTRIC'S

STEERING SERVO	TYPE <b>Futaba</b>	SETTINGS <b>BLS571SV</b>
ESC	TYPE <b>Yokomo BL-PRO4</b>	SETTINGS
ENGINE	TYPE <b>Yokomo</b>	SETTINGS <b>M3 - 17.5T</b>
TYRES/ADDITIVE	TYPE <b>Rush 28</b>	TYPE

FRONT FULL	<input type="checkbox"/>	REAR FULL	<input type="checkbox"/>
FRONT MIN.	<input type="checkbox"/>	REAR MIN.	<input type="checkbox"/>

### SHOCK ABSORBERS

FRONT REAR

PISTON **Kit** PISTON **Kit**

OIL **#450** OIL **#450**

SPRING **Xray 2.6** SPRING **Xray 2.6**

### ANTI ROLL BAR FRONT

1,2  1,3  1,4  1,5

### ANTI ROLL BAR REAR

1,1  1,2  1,3  1,4

### SERVO SAVER POSITION

FORWARD  REARWARD

PINION **38T** SPUR **114T**

DIFF **SPOOL**

HIGH  LOW

HIGH  LOW

DIFF OIL CST **#3,000~#5,000**

### SHOCK POSITION LOWER ARM

PART# **Kit** PART# **Kit**

HOLE POSITION BALL LINK INSIDE  OUTSIDE

HOLE POSITION BALL LINK INSIDE  OUTSIDE

### FLEX

ULTRAFLEX

TOPDECK

SCREW'S ASSEMBLED

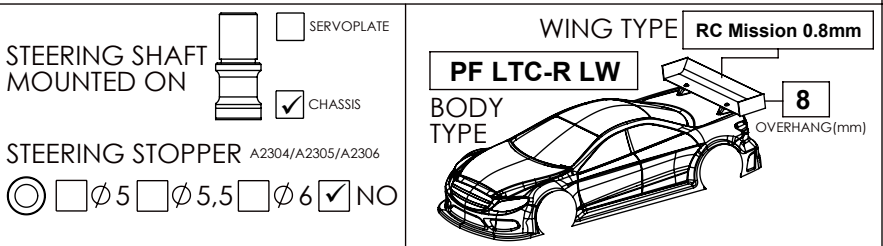
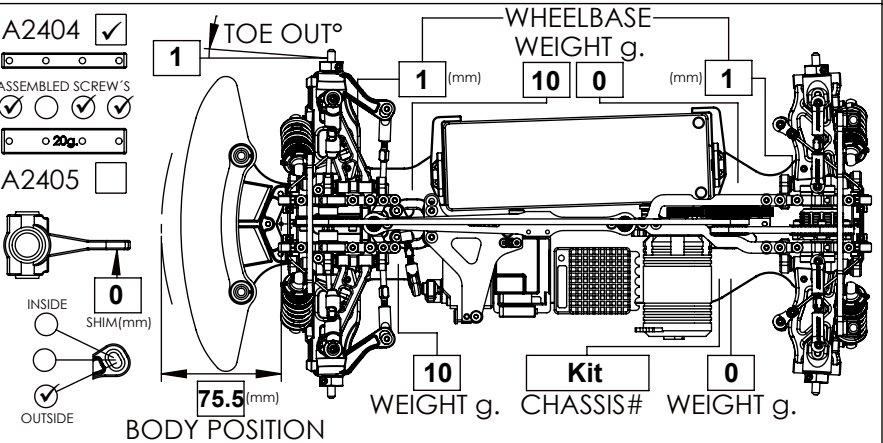
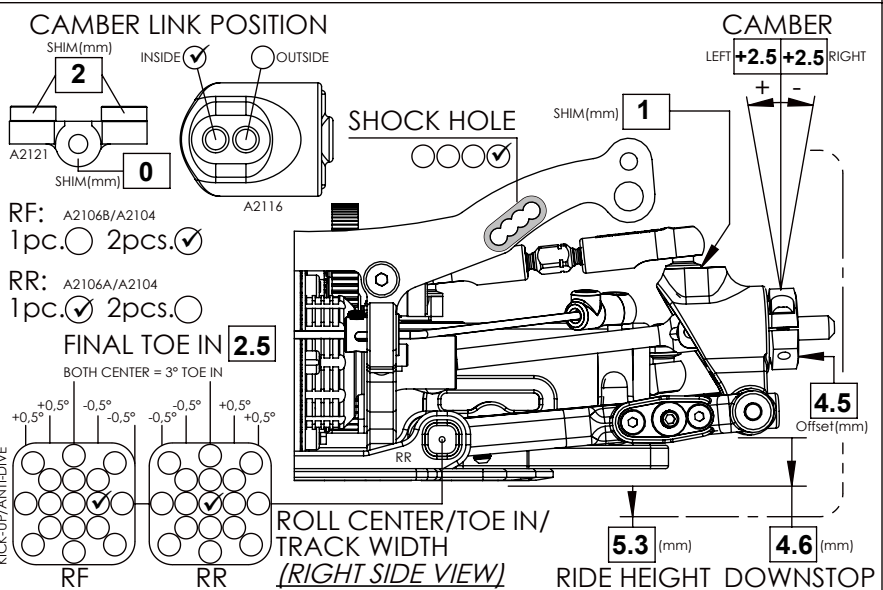
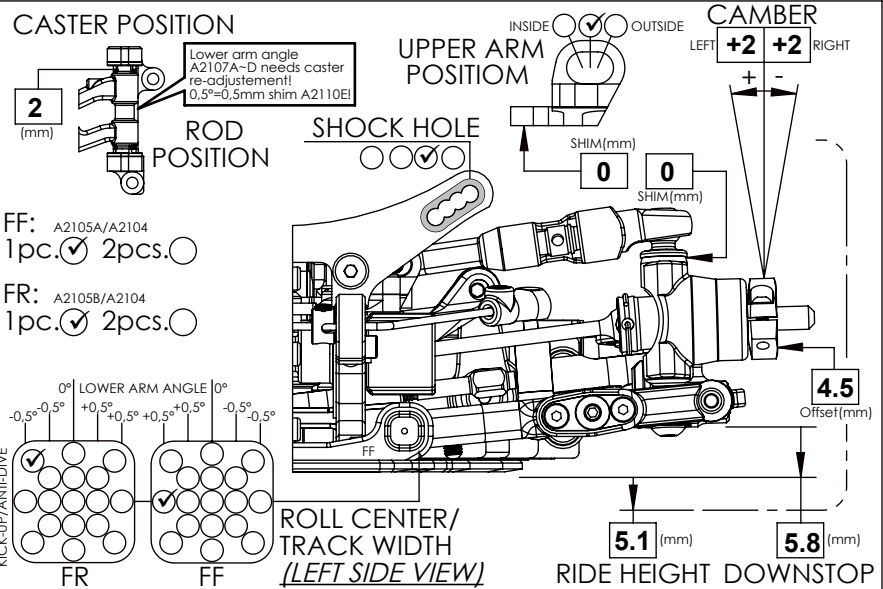

NOTES:

デフは路面状況により、#3,000~#5,000で調整する。  
Adjust the diff oil #3,000~#5,000 depending on the track condition.

サーボホーンはヨコモアルミ製  
Yokomo Alum Servo Horn