

Name: Robert Pietsch
Date: 2009/6/28
Track: Lostallo

Track Conditions
 Size: Open Med. Tight
 Traction: High Med. Low
 Surface: Smooth Med. Bumpy

Front suspension

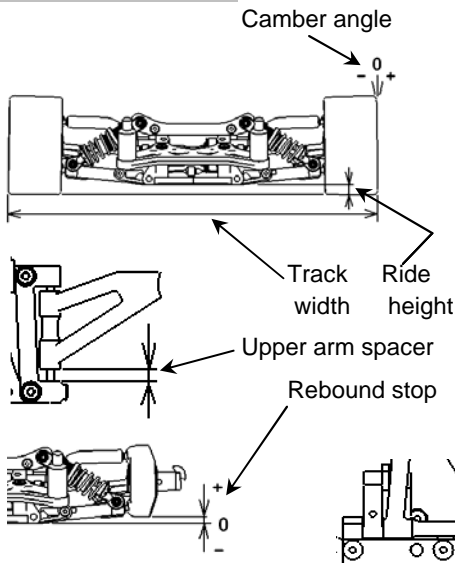

Track width 254 mm
 Ride height 7.0 mm
 Camber angle 2 °
 Upper arm spacer 2 mm
 Toe angle -3 °
 Rebound stop 2 mm
 Bump stop None Use
 Lower arm spacer 0 mm
 Upper arm position 1 mm
 Anti-roll bar

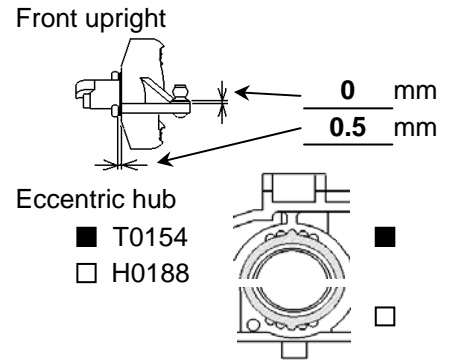

Steering ackerman

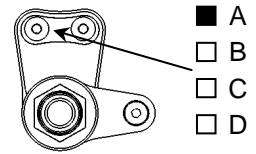

Rear suspension

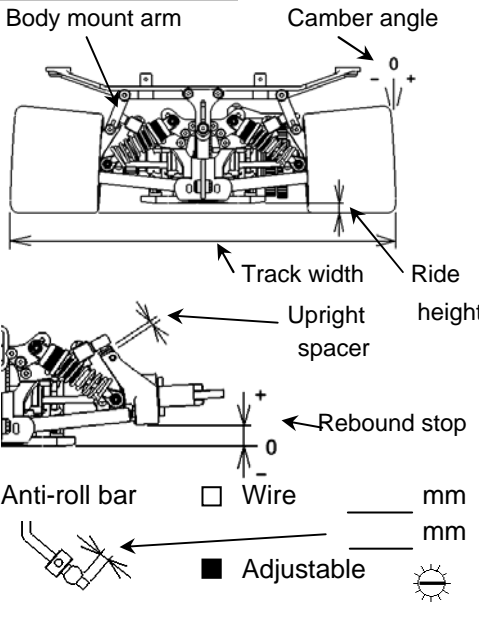

Track width 264 mm
 Ride height 8.0 mm
 Camber angle 2.5 - 3.0 °
 Toe angle 2.5 °
 Rebound stop 9 mm
 Bump stop None Use
 Lower arm position(H0134)
 4.5mm 5mm 5.5mm
 Upright spacer 3 mm
 Upper arm position
 Eccentric hub
 T0154
 H0188
 Body mount arm
 H0466C(Short)
 H0466F(Long)
 * special Long

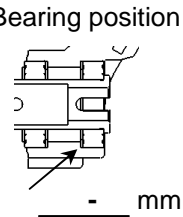

Front shock

Piston original
 Oil # 400
 Springs Grey
 Shock position

Rear shock

Piston original
 Oil # 600
 Springs Grey
 Shock position

Engine Type Novarossi Muffler 2015
 Gasket mm Manifold Short
 Plug 8tf Fuel MLC

Clutch
 Clutch shoe Yellow Gray Red
 Centrifugal shoe original
 Spring special
 Clutch bell clearance 0.7 mm
 Spring adj. nut position ap9.5 mm

Tire <Front> Type ATS 33 <Rear> Type ATS 35
 Dia.(start) L /R Dia.(start) L /R
 Dia.(finish) L /R Dia.(finish) L /R

Brake pad Black Yellow

Body Type Zytec
 Body position original rear point mm
 Rear spoiler 5 mm

Drive ratio Gear ratio Side pulley
 1st. 16/49 25T
 2nd. 20/45 26T

Result
 Race time / Lap
 Best lap (1Lap)

Comments:

