

Name: Marco Vanni
Date: 2009/6/28
Track: Lostallo Pre-Worlds

Track Conditions

Size: Open Med. Tight
 Traction: High Med. Low
 Surface: Smooth Med. Bumpy

Front suspension

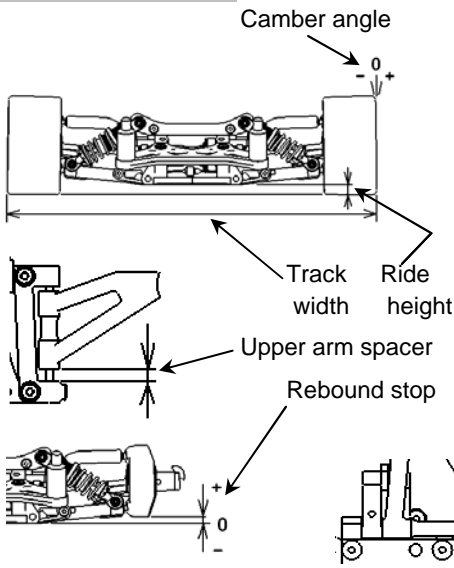

Track width 251 mm
 Ride height _____ mm
 Camber angle 0.5 - 1.5 °
 Upper arm spacer 2 mm
 Toe angle 1 - 1 °
 Rebound stop 2 mm
 Bump stop None Use
 Lower arm spacer 0 mm
 Upper arm position 1 mm
 Anti-roll bar

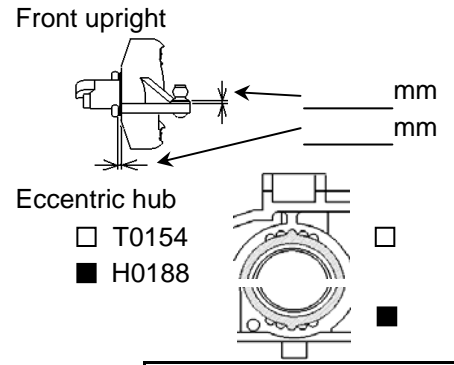

Steering ackerman

A
 B
 C
 D

Rear suspension

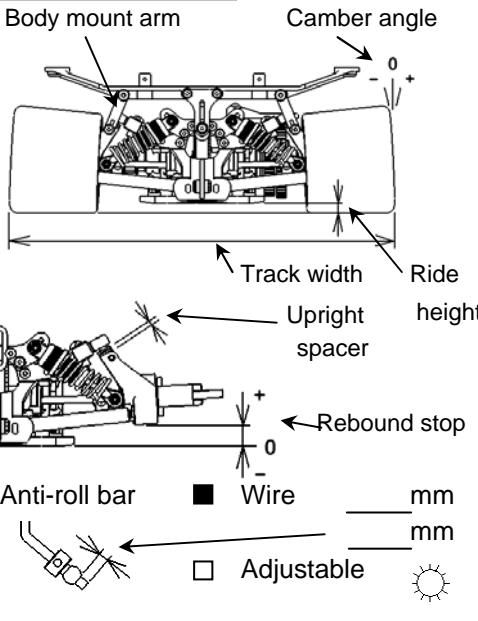

Track width 263 mm
 Ride height _____ mm
 Camber angle 2.0 - 2.5 °
 Toe angle 2.7 - 2.7 °
 Rebound stop 8 mm
 Bump stop None Use
 Lower arm position(H0134)
 4.5mm 5mm 5.5mm
 Upright spacer 1.5 mm
 Upper arm position _____ mm
 Eccentric hub
 T0154
 H0188
 Body mount arm
 H0466C(Short)
 H0466F(Long)

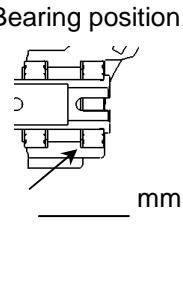

Front shock

Piston 1.2x1
 Oil # 600
 Springs White
 Shock position

Rear shock

Piston 1x2
 Oil # 500
 Springs White
 Shock position

Engine Type Novarossi Muffler 2015
 Gasket 8.5 mm Manifold _____
 Plug 7 cold Fuel _____

Clutch

Clutch shoe Yellow Gray Red
 Centrifugal shoe _____
 Spring _____
 Clutch bell clearance _____ mm
 Spring adj. nut position _____ mm

Tire <Front> Type Enneti <Rear> Type Enneti
 Dia.(start) L 70 /R 70 Dia.(start) L 77 /R 77
 Dia.(finish) L /R Dia.(finish) L /R

Brake pad Black Yellow

Body Type Zytec
 Body position 8 mm
 Rear spoiler 12 mm

Drive ratio Gear ratio Side pulley
 1st. 16/49 25T
 2nd. 20/45 26T

Result
 Race time / Lap _____
 Best lap (1Lap) 20.32

Comments:
Use H0139 Front Upright

