

Name: Robert Batlle
Date: November 2018
Track: 2018 Worlds Perth

Track conditions

Size: Open Med. Tight
 Traction: High Med. Low
 Surface: Smooth Med. Bumpy

Result

Race time / Lap: _____
 Best lap (1Lap): _____

Front suspension

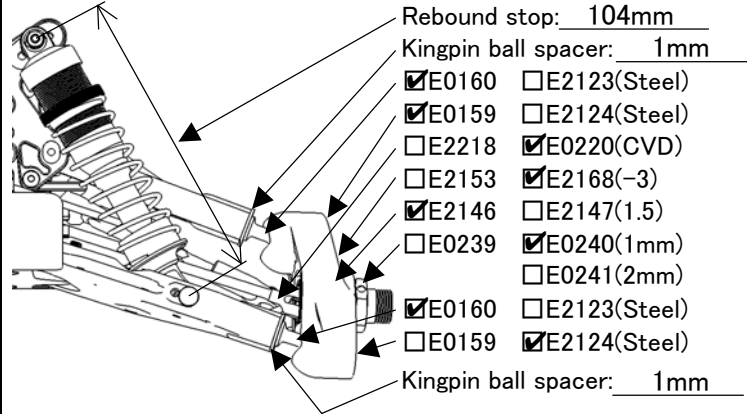

Rebound stop: 104mm
 Kingpin ball spacer: 1mm
 E0160 E2123(Steel)
 E0159 E2124(Steel)
 E2218 E0220(CVD)
 E2153 E2168(-3)
 E2146 E2147(1.5)
 E0239 E0240(1mm)
 E0239 E0241(2mm)
 E0160 E2123(Steel)
 E0159 E2124(Steel)
 Kingpin ball spacer: 1mm

Ride height: 24mm
 Toe angle: 29mm
 Lower arm plate:
 E2144A,B
 E2154(CFRP 1mm)
 E2155(CFRP 1.2mm)
 Anti roll bar: φ 2.4
 Upper arm spacer: Middle

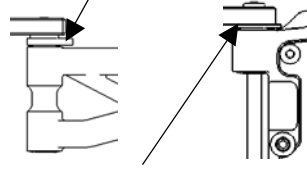

Upper arm position:

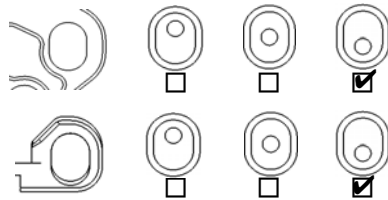

Lower arm position (Kick up):

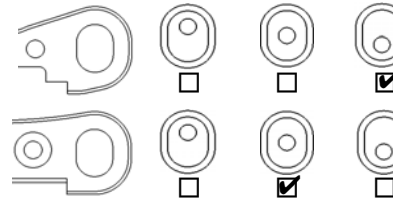

Lower arm spacer: 1mm

Front shocks

Piston: 8x1.2 Oil: #600
 Spring: 9.0
 Shock position:

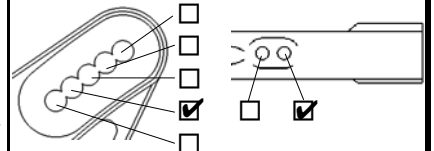

Pivot ball position: Front Rear
 Damper stay: E2562(Aluminum)
 E2565(CFRP)

Steering ackerman

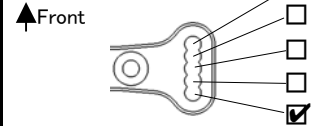

Front upper plate

E2148D E2158(CFRP)

Servo saver arm

E2301A E2310(Aluminum)

Rear suspension

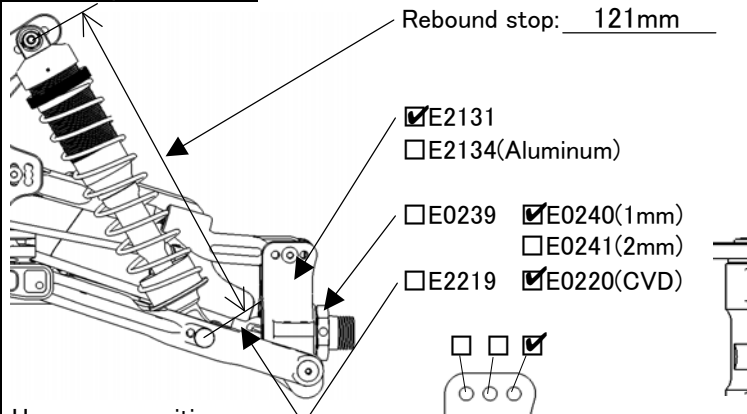

Rebound stop: 121mm
 E2131
 E2134(Aluminum)
 E0239 E0240(1mm)
 E2219 E0241(2mm)
 E0220(CVD)

Ride height: 27mm
 Camber angle: 19mm
 Lower arm plate:
 E2145A,B
 E2156(CFRP 1mm)
 E2157(CFRP 1.2mm)
 Anti roll bar: φ 2.7
 Lower arm spacer: 1mm

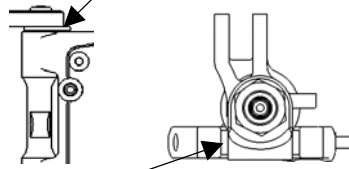

Upper arm position:

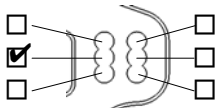

Lower arm position (Anti-squat):



Lower arm position (Toe angle):

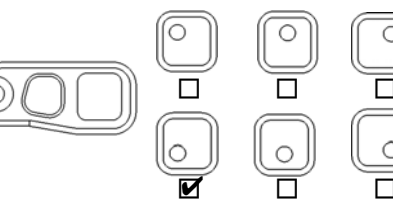

Upright spacer: 2mm

Rear shocks

Piston: 8x1.3 Oil: #600
 Spring: 10.5
 Shock position:

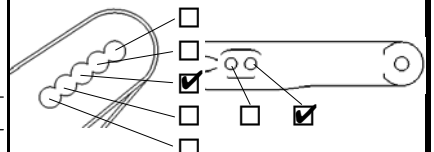

Pivot ball position: Front Rear
 Damper stay: E2563(Aluminum)
 E2566(CFRP)

Center shaft

E2228,E2229
 E0223,E0259(CVD) E2261,E2262

Tension rod

Front: E2107A(Long) E2107B(Short)
 Rear: E2148C E0803(Rubber)

Weight



Engine

Type: Ninja JX21-B04 Plug: P3 Reducer: 6.5mm
 Muffler: 2089 Fuel: _____ Gasket: _____
 Engine mount: E0701(Standard) E2713(One Piece)

Diff. gear

Oil
 Front: 44/13T 42/12T #15,000
 Rear: 44/13T 42/12T #7,000
 Center: 44T 46T #20,000
 47T 48T

Tires

	Front	Rear
Type:	<u>HotRace Alaska</u>	<u>HotRace Alaska</u>
Compound:	<u>Medium</u>	<u>Medium</u>
Inserts:	<u>Standard</u>	<u>Standard</u>
Wheel:	<u>Standard</u>	<u>Standard</u>

Clutch

Clutch bell: 13T 14T

		φ 0.9	φ 0.95	φ 1.0	φ 1.05	φ 1.1
A	<input checked="" type="checkbox"/> C0754 <input type="checkbox"/> E0704 <input type="checkbox"/> E0710			<input checked="" type="checkbox"/>		
B	<input checked="" type="checkbox"/> C0754 <input type="checkbox"/> E0704 <input type="checkbox"/> E0710			<input checked="" type="checkbox"/>		
C	<input checked="" type="checkbox"/> C0754 <input type="checkbox"/> E0704 <input type="checkbox"/> E0710			<input checked="" type="checkbox"/>		

Body/Wing

Body: Mugen
 Wing: HB
 Wing stay: E2422A E2428A(+15)
 Wing position:

Comments

.....

