

Name: Robert Battle  
 Date: 2018 GP Montpellier Warm-up  
 Track: Montpellier, France

**Track conditions**

Size:  Open  Med.  Tight  
 Traction:  High  Med.  Low  
 Surface:  Smooth  Med.  Bumpy

**Result**

Race time / Lap: \_\_\_\_\_  
 Best lap (1Lap): \_\_\_\_\_

**Front suspension**

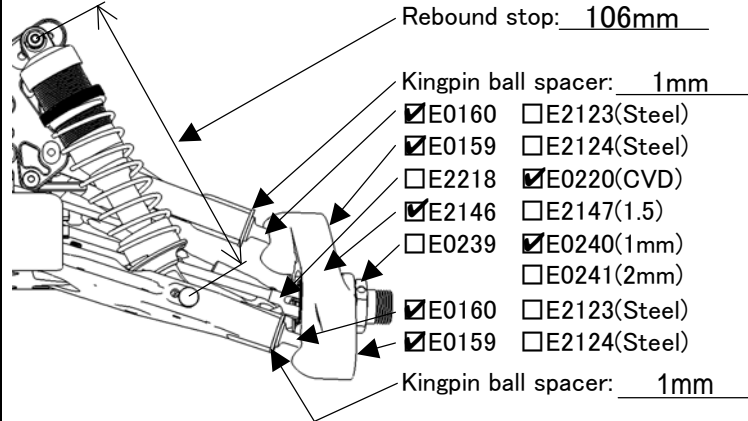

Ride height: 23mm  
 Toe angle: 26mm  
 Lower arm plate:  
 E2144A,B  
 E2154(CFRP 1mm)  
 E2155(CFRP 1.2mm)  
 Anti roll bar:  $\phi$  2.2  
 Upper arm spacer: Middle

**Front shocks**

Piston: 8x1.2 Oil: #400  
 Spring: 9.25  
 Shock position:  
      
 Pivot ball position:  Front  Rear  
 Damper stay:  E2562(Aluminum)  
 E2565(CFRP)

Upper arm position:

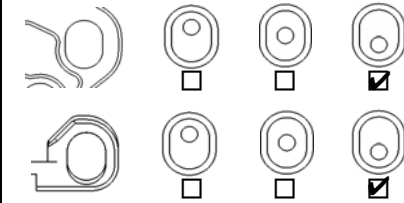

Lower arm position (Kick up):

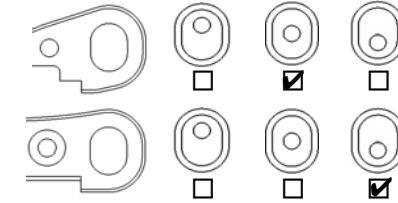

Lower arm spacer: 0

**Steering ackerman**

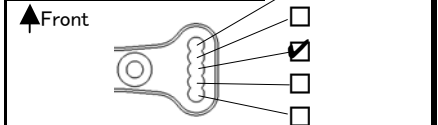

**Front upper plate**

E2148D  E2158(CFRP)

**Servo saver arm**

E2301A  E2310(Aluminum)

**Rear suspension**

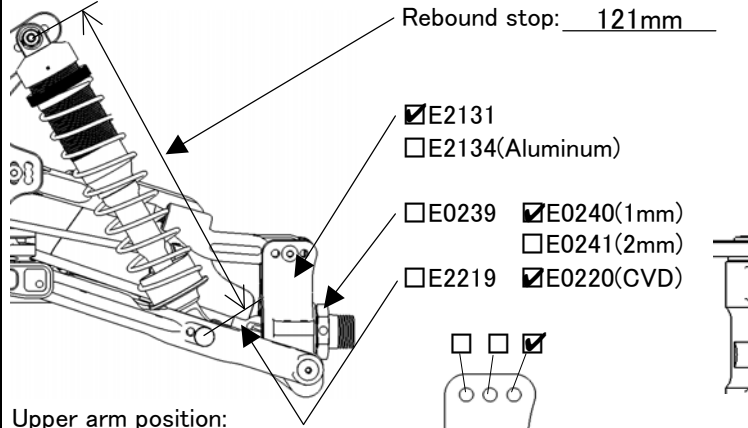

Ride height: 26mm  
 Camber angle: 19mm  
 Lower arm plate:  
 E2145A,B  
 E2156(CFRP 1mm)  
 E2157(CFRP 1.2mm)  
 Anti roll bar:  $\phi$  2.6  
 Lower arm spacer: 1mm

**Rear shocks**

Piston: 8x1.3 Oil: #400  
 Spring: 10.5  
 Shock position:  
      
 Pivot ball position:  Front  Rear  
 Damper stay:  E2563(Aluminum)  
 E2566(CFRP)

Upper arm position:

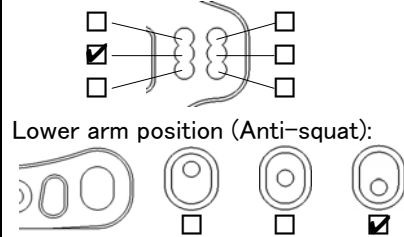

Lower arm position (Toe angle):

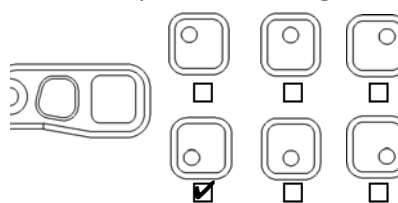

Upright spacer: 0mm

**Center shaft**

E0223,E0259  E2228,E2229

**Tension rod**

Front:  E2107A(Long)  E2107B(Short)  
 Rear:  E2148C  E0803(Rubber)

**Weight**



**Engine**

Type: Ninja JX21-B04 Plug: P3 Reducer: 6.5mm  
 Muffler: Ninja 2089 Fuel: Corally Gasket: \_\_\_\_\_  
 Engine mount:  E0701(Standard)  Other One piece

**Diff. Gear**

Oil  
 Front:  44/13T  42/12T #5,000  
 Rear:  44/13T  42/12T #5,000  
 Center:  44T  46T #3,000  
 47T  48T

**Tires**

	Front	Rear
Type:	<u>HotRace Amazonia</u>	<u>HotRace Amazonia</u>
Compound:	<u>Soft</u>	<u>Soft</u>
Inserts:	<u>Standard</u>	<u>Standard</u>
Wheel:	<u>Standard</u>	<u>Standard</u>

**Clutch**

3P  4P  
 Clutch bell:  13T  14T  
 Clutch shoes  C0754  E0704  E0710  E2706  
 Clutch spring  0.8  0.9  0.95  1.0  1.05  1.1

**Body/Wing**

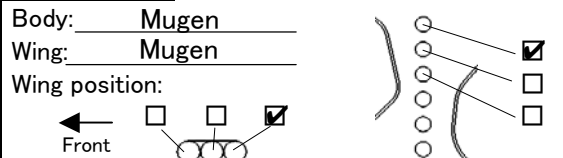

**Comments**

+5mm rear shock stand.  
 \_\_\_\_\_  
 \_\_\_\_\_  
 \_\_\_\_\_