

**Name:** Kenji Tsuruta  
**Date:** FEMCA 2018  
**Track:** Banana RC Track, Indonesia

**Track conditions**  
 Size:  Open  Med.  Tight  
 Traction:  High  Med.  Low  
 Surface:  Smooth  Med.  Bumpy

**Result**  
 Race time / Lap: \_\_\_\_\_  
 Best lap (1Lap): \_\_\_\_\_

**Front suspension**

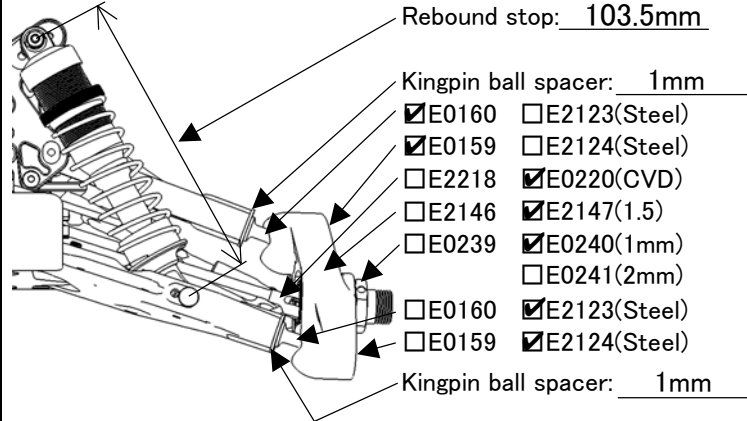

Ride height: 24mm  
 Toe angle: 25.8mm  
 Lower arm plate:  
 E2144A,B  
 E2154(CFRP 1mm)  
 E2155(CFRP 1.2mm)  
 Anti roll bar:  $\phi$  2.2  
 Upper arm spacer: 2mm  
 Lower arm spacer: 0mm

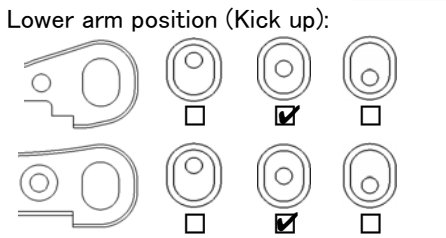
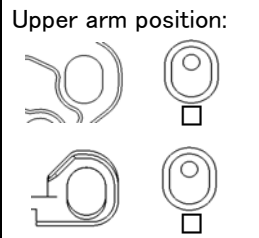

**Front shocks**

Piston: 4x1.0, 4x1.4 Oil: #650  
 Spring: 9.5  
 Shock position:  
      
 Pivot ball position:  Front  Rear  
 Damper stay:  E2562(Aluminum)  
 E2565(CFRP)

**Steering ackerman**

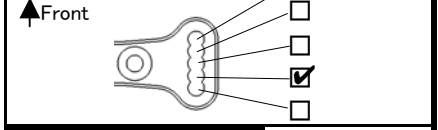

**Front upper plate**

E2148D  E2158(CFRP)

**Servo saver arm**

E2301A  E2310(Aluminum)

**Rear suspension**

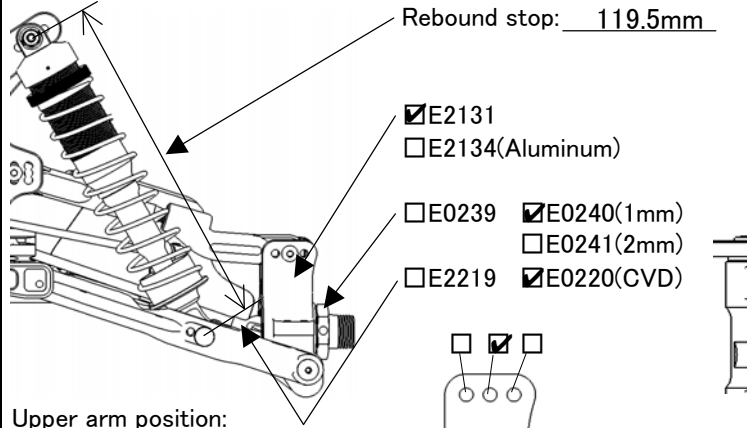

Ride height: 28mm  
 Camber angle: 14.5mm  
 Lower arm plate:  
 E2145A,B  
 E2156(CFRP 1mm)  
 E2157(CFRP 1.2mm)  
 Anti roll bar:  $\phi$  2.6  
 Lower arm spacer: 1mm  
 Upright spacer: 1.5mm

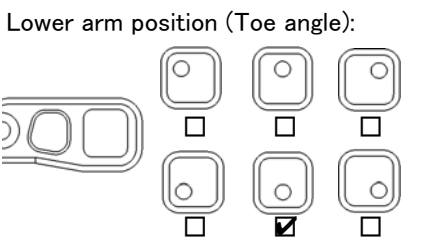
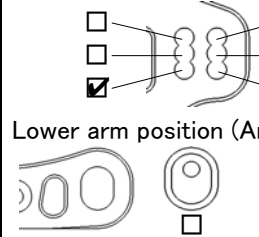

**Rear shocks**

Piston: 4x1.0, 4x1.4 Oil: #600  
 Spring: 10.75  
 Shock position:  
      
 Pivot ball position:  Front  Rear  
 Damper stay:  E2563(Aluminum)  
 E2566(CFRP)

**Center shaft**

E0223,E0259  E2228,E2229

**Tension rod**

Front:  E2107A(Long)  E2107B(Short)  
 Rear:  E2148C  E0803(Rubber)

**Weight**



**Engine**  
 Type: Ninja JX21-B04 Plug: P3 Reducer: 6.5  
 Muffler: Ninja 2042 Fuel: VP Tessmann Gasket: \_\_\_\_\_  
 Engine mount:  E0701(Standard)  Other One piece

**Diff. Gear**  
 Front:  44/13T  42/12T Oil #5,000  
 Rear:  44/13T  42/12T #3,000  
 Center:  44T  46T #5,000  
 47T  48T

**Tires**

	Front	Rear
Type:	<u>Pro-Line ElectroShot</u>	<u>Pro-Line ElectroShot</u>
Compound:	<u>X3</u>	<u>X3</u>
Inserts:	<u>Pro-Line</u>	<u>Pro-Line</u>
Wheel:	<u>Mugen</u>	<u>Mugen</u>

**Clutch**  3P  4P  
 Clutch bell:  13T  14T  
 Clutch shoes  C0754  E0704  E0710  E2706  
 Clutch spring  0.8  0.9  0.95  1.0  1.05  1.1

**Body/Wing**

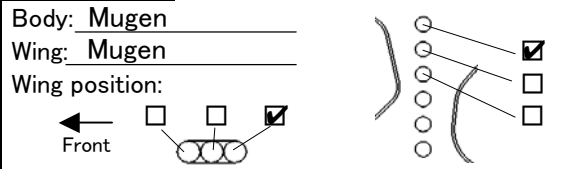

**Comments**

フロント、リアのデフのシムをすべて使用しない。  
 Without any shims in the front & rear differential  
 E0710 x 1