

**Name:** Juan Carlos Canas  
**Date:** NEO 2018  
**Track:** RC Redovan, Spain

### Track conditions

Size: Open Med. Tight  
 Traction: High Med. Low  
 Surface: Smooth Med. Bumpy

### Result

Race time / Lap: \_\_\_\_\_  
 Best lap (1Lap): \_\_\_\_\_

### Front suspension

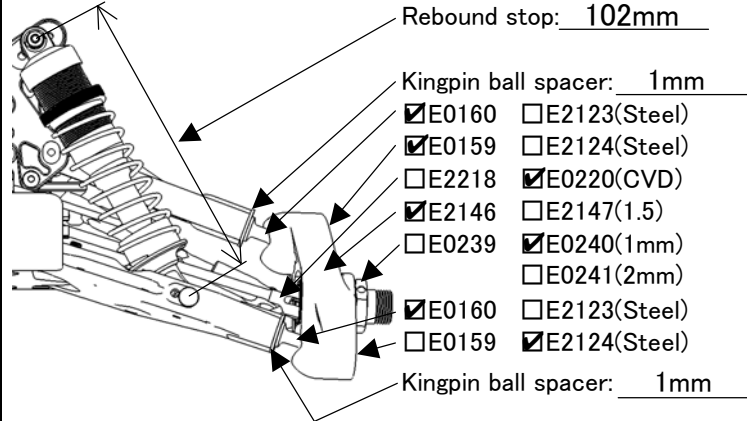

Ride height: 24mm  
 Toe angle: 26mm  
 Lower arm plate:  
E2144A,B  
E2154(CFRP 1mm)  
E2155(CFRP 1.2mm)  
 Anti roll bar:  $\phi$  2.3  
 Upper arm spacer: 2mm  
 Lower arm spacer: 0mm

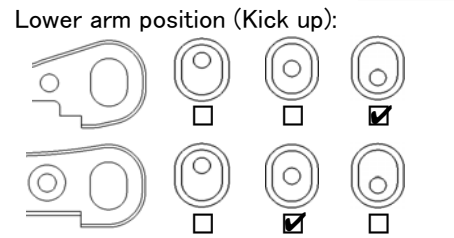
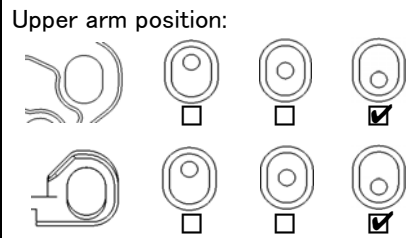

### Front shocks

Piston: 1.2 UR Oil: #550  
 Spring: 9.25  
 Shock position:  
  
  
  
  
 Pivot ball position: Front Rear  
 Damper stay: E2562(Aluminum)  
E2565(CFRP)

### Steering ackerman

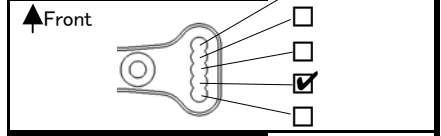

### Front upper plate

E2148D E2158(CFRP)

### Servo saver arm

E2301A E2310(Aluminum)

### Rear suspension

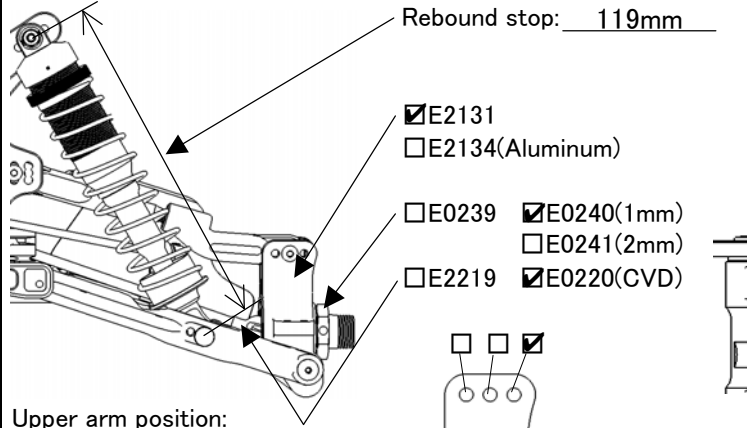

Ride height: 28mm  
 Camber angle: 19mm  
 Lower arm plate:  
E2145A,B  
E2156(CFRP 1mm)  
E2157(CFRP 1.2mm)  
 Anti roll bar:  $\phi$  2.7  
 Lower arm spacer: 1mm  
 Upright spacer: 0mm

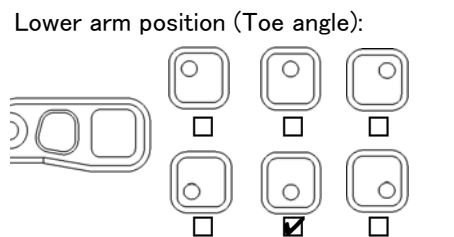
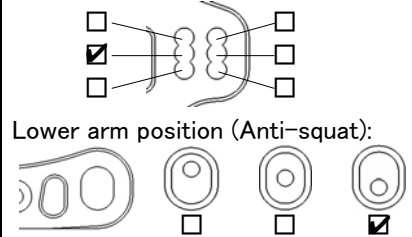

### Rear shocks

Piston: 8x1.3 Oil: #500  
 Spring: 10.5  
 Shock position:  
  
  
  
  
 Pivot ball position: Front Rear  
 Damper stay: E2563(Aluminum)  
E2566(CFRP)

### Center shaft

E0223,E0259 E2228,E2229

### Tension rod

Front: E2107A(Long) E2107B(Short)  
 Rear: E2148C E0803(Rubber)

### Weight



### Engine

Type: Ultimate M3T Plug: P3 Reducer: \_\_\_\_\_  
 Muffler: UR 2141 Fuel: NITROLUX 25 Gasket: \_\_\_\_\_  
 Engine mount: E0701(Standard) Other One piece

### Diff. Gear

Oil  
 Front: 44/13T 42/12T #6,000  
 Rear: 44/13T 42/12T #7,000  
 Center: 44T 46T #3,000  
47T 48T

### Tires

	Front	Rear
Type:	<u>Procircuit CLAYMORE</u>	<u>Procircuit CLAYMORE</u>
Compound:	<u>P2 (Soft)</u>	<u>P2 (Soft)</u>
Inserts:	<u>Procircuit</u>	<u>Procircuit</u>
Wheel:	<u>Procircuit</u>	<u>Procircuit</u>

### Clutch

3P 4P  
 Clutch bell: 13T 14T  
 Clutch shoes C0754 E0704 E0710 E2706  
 Clutch spring 0.8 0.9 0.95 1.0 1.05 1.1

### Body/Wing

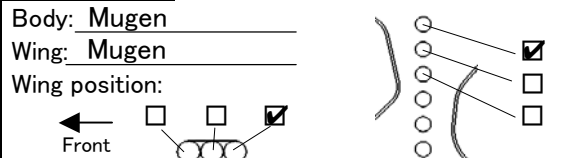

### Comments

+5mm Rear Shocks Stand  
 B10 Ultimate Compak V2 Clutch System