

Name: Atsushi Hara
Date: O.S. Off-Road Challenge 2018
Track: Yoshino-Works, Shiojiri, Japan

Track conditions

Size: Open Med. Tight
 Traction: High Med. Low
 Surface: Smooth Med. Bumpy

Result

Race time / Lap: _____
 Best lap (1Lap): _____

Front suspension

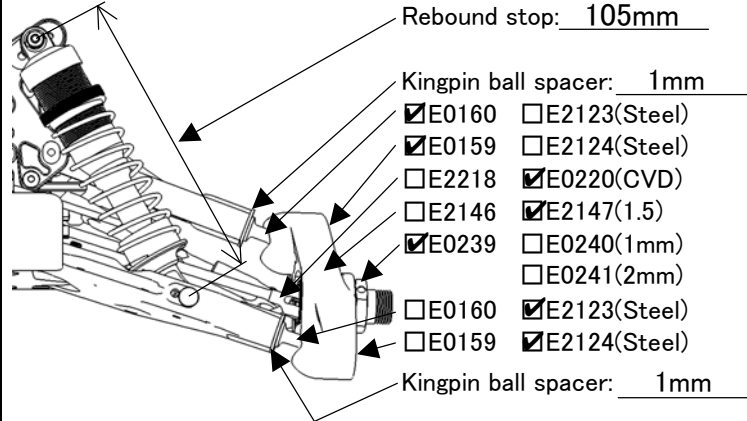

Upper arm position:

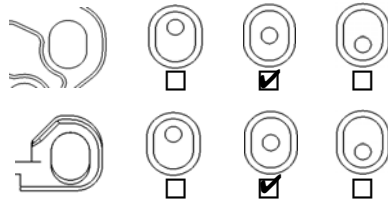

Rear suspension

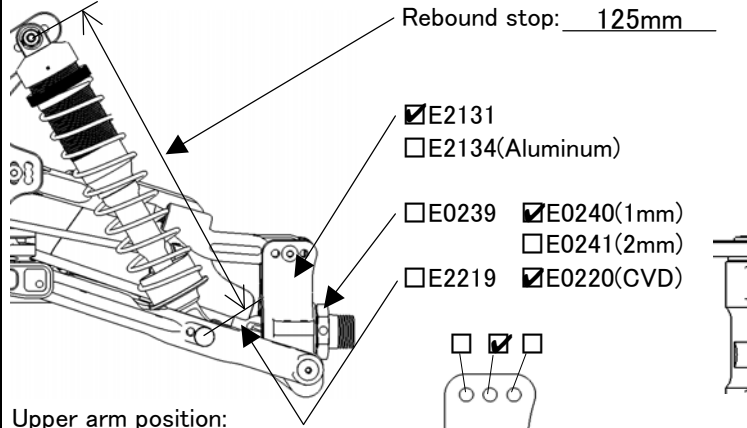

Upper arm position:

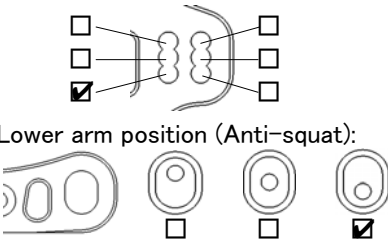

Lower arm position (Anti-squat):



Lower arm position (Kick up):

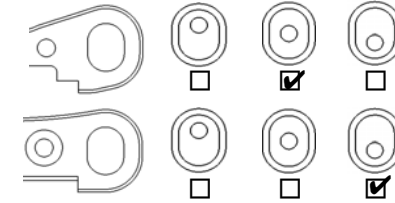

Ride height: 23mm
 Toe angle: 25.9mm
 Lower arm plate: E2144A,B
E2154(CFRP 1mm)
E2155(CFRP 1.2mm)
 Anti roll bar: ϕ 2.3
 Upper arm spacer: 4mm
 Lower arm spacer: 1mm

Front shocks

Piston: 1.3x8 Oil: #600
 Spring: 9.5
 Shock position:

 Pivot ball position: Front Rear
 Damper stay: E2562(Aluminum)
E2565(CFRP)

Steering ackerman

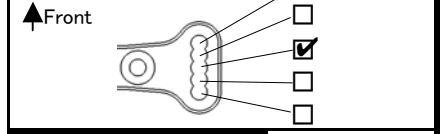

Front upper plate

E2148D E2158(CFRP)

Servo saver arm

E2301A E2310(Aluminum)

Rear shocks

Piston: 1.3x8 Oil: #600
 Spring: 10.75
 Shock position:

 Pivot ball position: Front Rear
 Damper stay: E2563(Aluminum)
E2566(CFRP)

Center shaft

E0223,E0259 E2228,E2229

Tension rod

Front: E2107A(Long) E2107B(Short)
 Rear: E2148C E0803(Rubber)

Weight



Engine

Type: O.S Speed B2101 Plug: P3 Reducer: 6
 Muffler: O.S 2060 Fuel: Nitrox Gasket: _____
 Engine mount: E0701(Standard) Other One piece

Diff. Gear

Oil
 Front: 44/13T 42/12T #4,000
 Rear: 44/13T 42/12T #2,000
 Center: 44T 46T #4,000
47T 48T

Tires

	Front	Rear
Type:	Pro-Line Blockade	Pro-Line Blockade
Compound:	X4	X4
Inserts:	Pro-Line	Pro-Line
Wheel:	Mugen	Mugen

Clutch

3P 4P
 Clutch bell: 13T 14T
 Clutch shoes C0754 E0704 E0710 E2706
 Clutch spring 0.8 0.9 0.95 1.0 1.05 1.1

Body/Wing

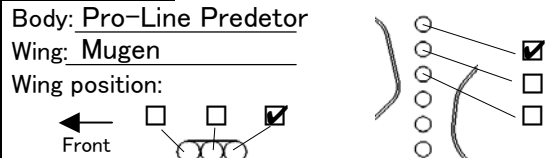

Comments

- ・フロントデフはデフギヤ20のシムを使用しない。(To not use the shims of the diff gear 20 on the front diff)
- ・センター、リアのデフはデフギヤ20、10のシムをすべて使用しない。(To not use the shims of the diff gear 20, 10 on the center/rear diff)
- ・リバウンドの計測は外穴の中心までを測定した数値です。(The rebound measurement is a value measured up to the center of the outer hole)
- ・リヤダンパーステーはE2563Bを使用。(Use E2563B)
- ・C0754, E0710に1.05, E0710に0.95を使用。(Use C0754, E0710:1.05, E0710: 0.95)