

Name: Atsushi Hara
 Date: FEMCA 2018
 Track: Banana RC Track, Indonesia

Track conditions

Size: Open Med. Tight
 Traction: High Med. Low
 Surface: Smooth Med. Bumpy

Result

Race time / Lap: _____
 Best lap (1Lap): _____

Front suspension

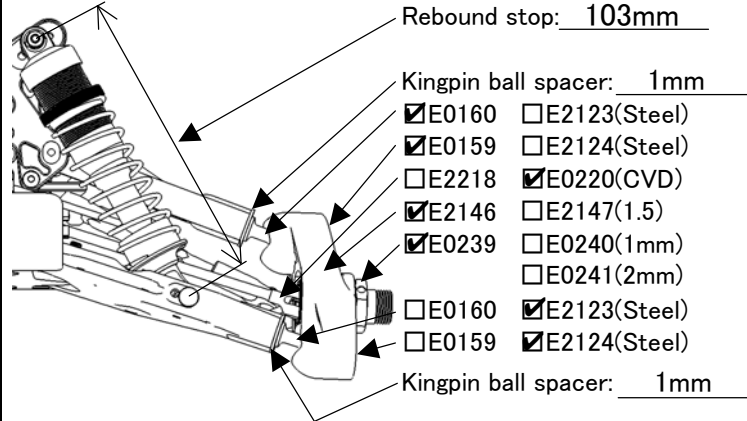

Upper arm position:

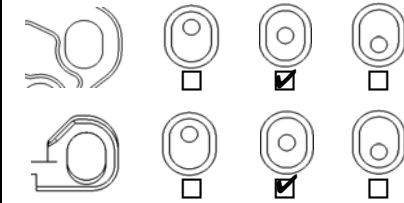

Lower arm position (Kick up):

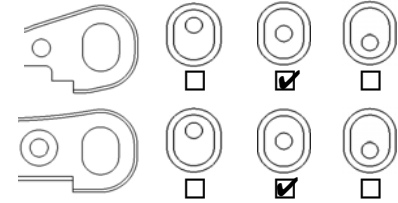

Ride height: 24mm
 Toe angle: 25.8mm
 Lower arm plate:
 E2144A,B
 E2154(CFRP 1mm)
 E2155(CFRP 1.2mm)
 Anti roll bar: ϕ 2.2
 Upper arm spacer: 2mm

 Lower arm spacer: 1mm

Front shocks

Piston: 4x1.0, 4x1.4 Oil: #600
 Spring: 9.25
 Shock position:

 Pivot ball position: Front Rear
 Damper stay: E2562(Aluminum)
 E2565(CFRP)

Steering ackerman

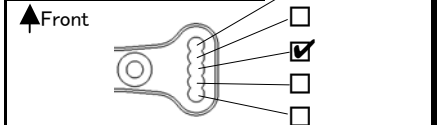

Front upper plate

E2148D E2158(CFRP)

Servo saver arm

E2301A E2310(Aluminum)

Rear suspension

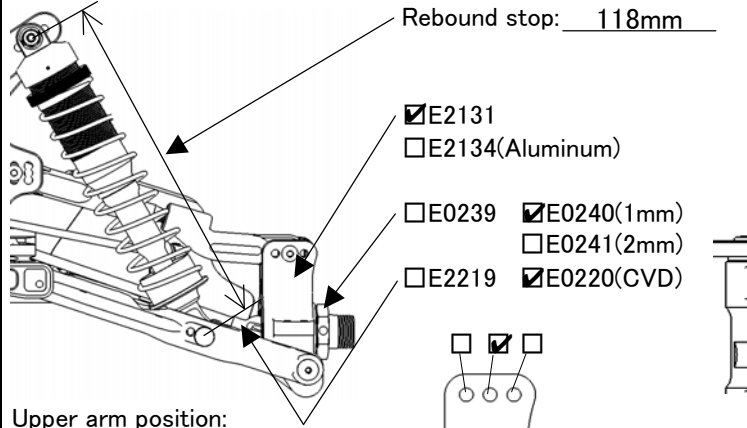

Upper arm position:

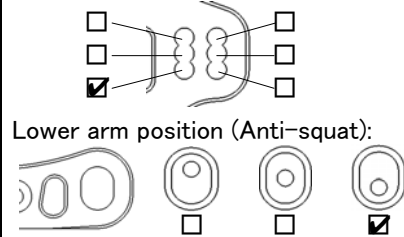

Lower arm position (Toe angle):

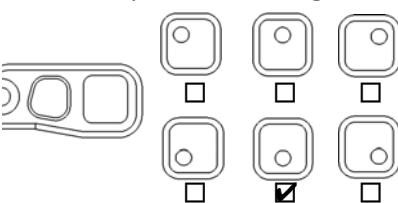

Ride height: 28mm
 Camber angle: 14.5mm
 Lower arm plate:
 E2145A,B
 E2156(CFRP 1mm)
 E2157(CFRP 1.2mm)
 Anti roll bar: ϕ 2.6
 Lower arm spacer: 0mm

 Upright spacer: 2.5mm

Rear shocks

Piston: 4x1.0, 4x1.4 Oil: #550
 Spring: 10.75
 Shock position:

 Pivot ball position: Front Rear
 Damper stay: E2563(Aluminum)
 E2566(CFRP)

Center shaft

E0223,E0259 E2228,E2229

Tension rod

Front: E2107A(Long) E2107B(Short)
 Rear: E2148C E0803(Rubber)

Weight



Engine
 Type: O.S Speed B21 Adam Drake Plug: P3 Reducer: 6
 Muffler: O.S 2090 Fuel: VP Tessmann Gasket: _____
 Engine mount: E0701(Standard) Other One piece

Diff. Gear

| | | Oil |
|---------|--|--------|
| Front: | <input type="checkbox"/> 44/13T <input checked="" type="checkbox"/> 42/12T | #4,000 |
| Rear: | <input type="checkbox"/> 44/13T <input checked="" type="checkbox"/> 42/12T | #2,000 |
| Center: | <input type="checkbox"/> 44T <input type="checkbox"/> 46T | #4,000 |
| | <input checked="" type="checkbox"/> 47T <input type="checkbox"/> 48T | |

Tires

| | Front | Rear |
|-----------|-----------------------------|-----------------------------|
| Type: | <u>Pro-Line ElectroShot</u> | <u>Pro-Line ElectroShot</u> |
| Compound: | <u>X3</u> | <u>X3</u> |
| Inserts: | <u>Pro-Line</u> | <u>Pro-Line</u> |
| Wheel: | <u>Mugen</u> | <u>Mugen</u> |

Clutch 3P 4P
 Clutch bell: 13T 14T
 Clutch shoes C0754 E0704 E0710 E2706
 Clutch spring 0.8 0.9 0.95 1.0 1.05 1.1

Body/Wing

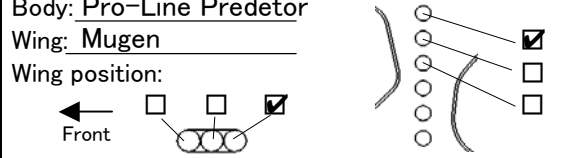

Comments

フロント、リアのデフのシムをすべて使用しない。
 Without any shims in the front & rear differential
 センターのデフのOW6x12x0.2シムx2枚を使用しない。
 Without two-shims (OW6x12x0.2) in the center differential
 E0710 x 2