

Name: Robert Batlle
Date: 8/16/2015
Track: Fehring Euros (Austria)

Track Conditions
 Size: Open Med. Tight
 Traction: High Med. Low
 Surface: Smooth Med. Bumpy

Result
 Race Time / Lap: _____
 Best Lap (1Lap): _____

Front Suspension

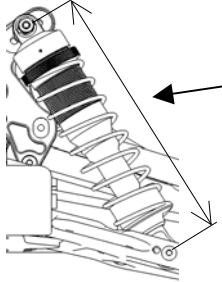

Rebound Stop: 103mm

Upright: E2129 E2105-B
 Tension Rod: E2107A(Long) E2107B(Short)

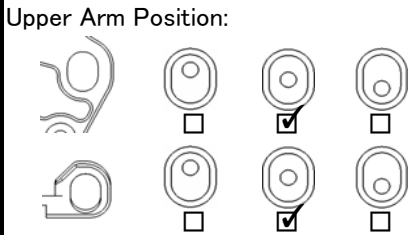

Ride Height: 23mm
 Toe Angle: 25.2mm
 Kingpin Ball Spacer(Upper): 1mm
 (Lower): 1mm
 Wheel Hub: +1mm
 Anti Roll Bar: 2.4
 Upper Arm Spacer: Medium

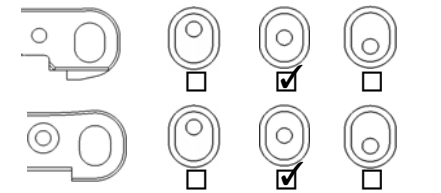
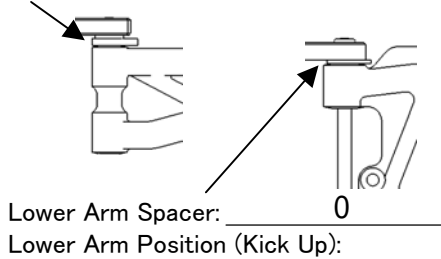

Front Shocks

Piston: 1.2x8
 Oil: #550
 Spring: 7.75T (Silver)

Shock Position:

Pivot Ball Position: Front Rear
 Damper Stay: E2502(Aluminum) E2511(CFRP)

Steering Ackerman

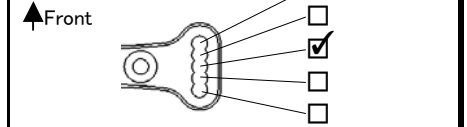

Rear Suspension

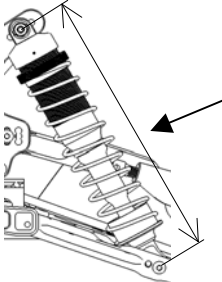

Rebound Stop: 117mm

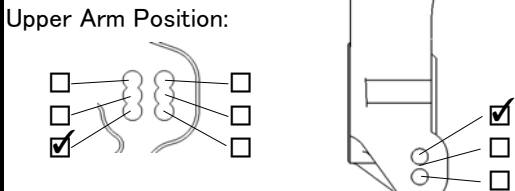

Ride Height: 27mm
 Camber Angle: -3°
 Wheel Hub: +1mm
 Anti Roll Bar: 2.7
 Lower Arm Spacer: 1

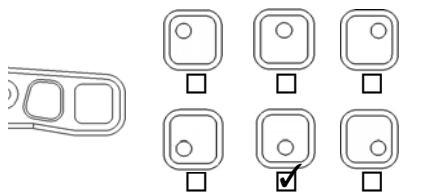
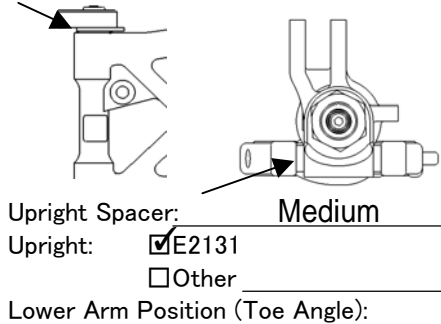

Rear Shocks

Piston: 1.2x8
 Oil: #450
 Spring: 10.5T

Shock Position:

Pivot Ball Position: Front Rear
 Damper Stay: E2522(Aluminum) E2523(CFRP)

Weight

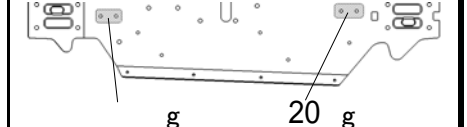

Power Train

Motor: LRP 2,200
 ESC: LRP IX8 V2
 Battery: LRP 7000

Diff. Oil

Front: #7,000 O-Ring: _____ pcs.
 Center: #7,000 _____ pcs.
 Rear: #3,000 _____ pcs.

Tires

	Front	Rear
Type:	<u>Procircuit Hot Dices</u>	<u>Procircuit Hot Dices</u>
Compound:	<u>Medium</u>	<u>Medium</u>
Inserts:	_____	_____
Wheel:	_____	_____

Gearing

Pinion Gear: 14 T
 Spur Gear: 44T(E0255) 46T(E0256)

Body/Wing

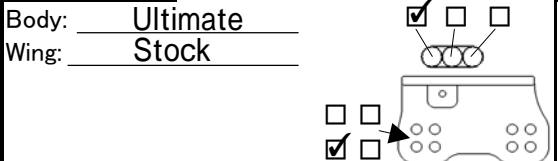

Comments

.....

