

**Name:** Kenji Osaka  
**Date:** 8/26/2012  
**Track:** FEMCA 2012 Asian Buggy Championship

### Track Conditions

Size:  Open  Med.  Tight  
 Traction:  High  Med.  Low  
 Surface:  Smooth  Med.  Bumpy

### Front Suspension

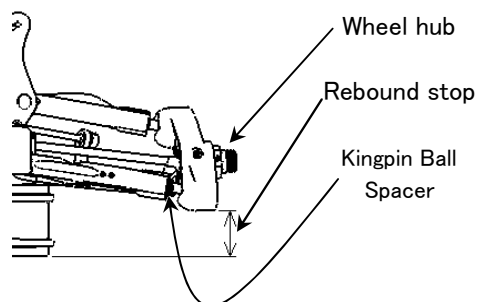

Kingpin ball spacer 1 mm  
 Camber angle -1.5 °  
 Upper arm spacer 2 mm  
 Toe angle out 1 °  
 Rebound stop 18 mm  
 Anti-roll bar  $\phi$  2.4 mm  
 Wheel Hub 0 mm  
 Lower arm mount (Kick up)



Lower arm plate (E0154A)  0  1

Upper arm position (E0148B, E0148C)



Lower arm spacer 1 mm

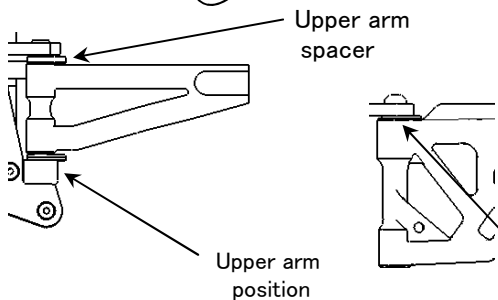

### Front Shocks

Piston 1.35 Taper  
 Oil # 600  
 Spring L75-8.25  
 Spring adjustment \_\_\_\_\_ mm

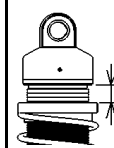

Shock position

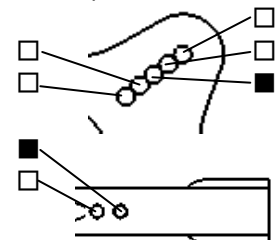

### Steering Ackerman



### Rear Suspension

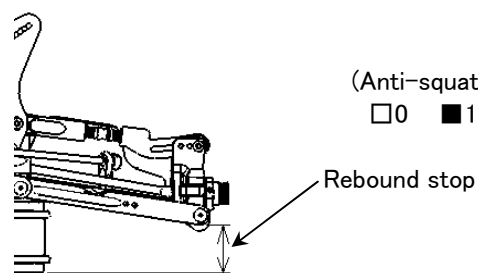

Camber angle -2.5 °  
 Lower arm mount  E0185(Aluminium)  
 (Anti-squat)  0  1  
 (Toe angle) 2.75 °

Rebound stop 18 mm  
 Anti-roll bar  $\phi$  2.9 mm  
 Anti-squat (E0111C, E0111D)

Upright  E0152  E0173(Aluminium)

Wheelbase adjustment

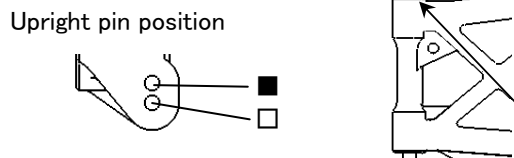
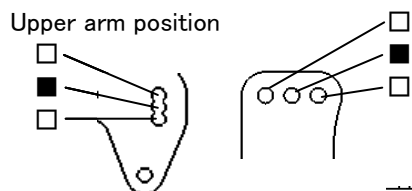
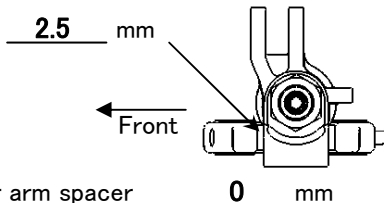

### Rear Shocks

Piston 1.35 Taper  
 Oil # 550  
 Spring L86-8.25  
 Spring adjustment \_\_\_\_\_ mm

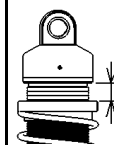

Shock position

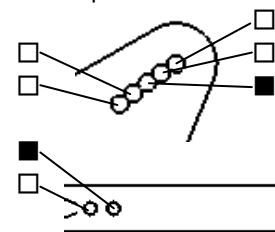

### Wing Position

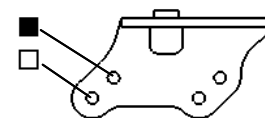

**Engine** Type Ninja JX21-B02  
 Gasket \_\_\_\_\_ mm Reducer  $\phi$  6  
 Plug 4 Fuel MSRF 25  
 Muffler Ninja EFRA2042

**Diff. Oil**  
 Front # 10000 O-Ring \_\_\_\_\_ pcs.  Other \_\_\_\_\_  
 Center # 7000 \_\_\_\_\_ pcs.  Other \_\_\_\_\_  
 Rear # 4000 \_\_\_\_\_ pcs.  Other \_\_\_\_\_

**Tire**  
 Front Type Gridlock Rear Type Gridlock  
 Foam \_\_\_\_\_ Foam \_\_\_\_\_

**Clutch**  
 Clutch shoes  Aluminium \_\_\_\_\_  
 Other \_\_\_\_\_  
 Spring 1.1 1.05 1.0 mm  
 Clutch bell / Spur gear 13T / 44T

**Result**  
 Race time / Lap \_\_\_\_\_  
 Best lap (1Lap) \_\_\_\_\_

**Comments:** Use MBX6 ECO Body  
 \_\_\_\_\_  
 \_\_\_\_\_  
 \_\_\_\_\_