

**Name:** Kenji Osaka  
**Date:** December 9-13, 2009  
**Track:** Buggy Party in Pattaya, Thailand

### Track Conditions

Size:  Open  Med.  Tight  
 Traction:  High  Med.  Low  
 Surface:  Smooth  Med.  Bumpy

### Front Suspension

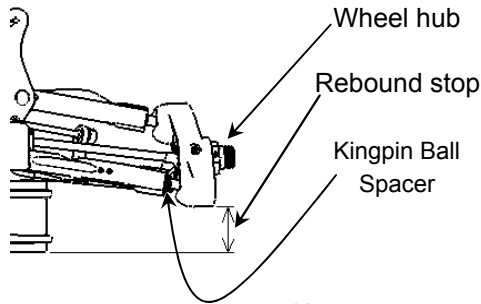

Kingpin ball spacer 2 mm  
 Camber angle -1.5 °  
 Upper arm spacer 2 mm  
 Toe angle out 1 °  
 Rebound stop 10 mm  
 Anti-roll bar  $\phi$  2.3 mm  
 Wheel Hub 0 mm  
 Lower arm mount (Kick up)  0  1



Lower arm plate (E0154A)

Upper arm position (E0148B, E0148C)

Lower arm spacer 1 mm

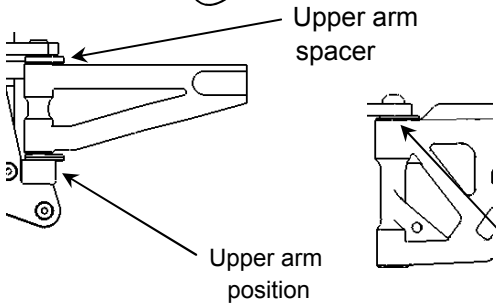

### Front Shocks

Piston 1.35x5 Tapered  
 Oil # 450  
 Spring 9.75  
 Spring adjustmer \_\_\_\_\_ mm

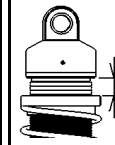

Shock position

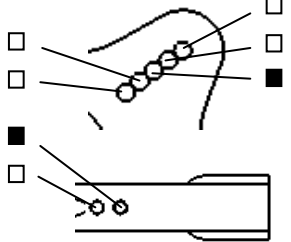

### Steering Ackerman

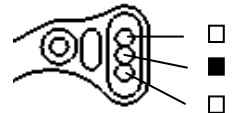

### Rear Suspension

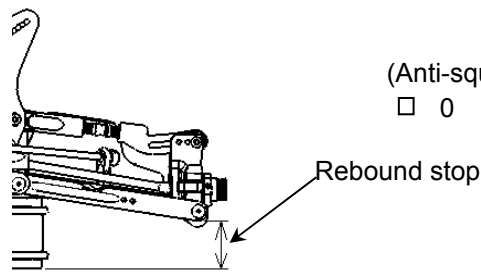

Camber angle -2.5 °  
 Lower arm mount (Anti-squat)  0  1 (Toe angle) 2.75 °  
 Rebound stop 10 mm  
 Anti-roll bar  $\phi$  2.9 mm  
 Anti-squat (E0111C, E0111D)

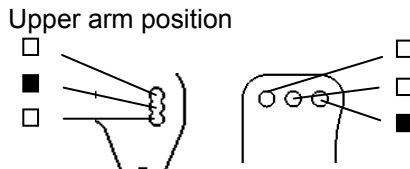

Upright  E0152  E0173 (Aluminium)

Wheelbase adjustment

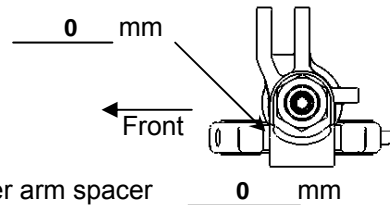

Lower arm spacer 0 mm

### Rear Shocks

Piston 1.35x5 Tapered  
 Oil # 450  
 Spring 10.75  
 Spring adjustmer \_\_\_\_\_ mm

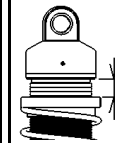

Shock position

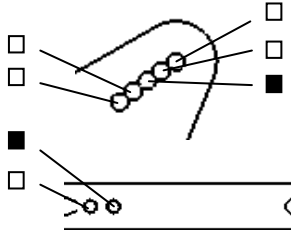

### Wing Position

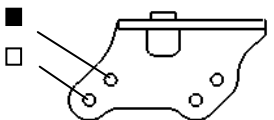

Engine	Type	Ninja JX21-B01A	
Gasket	<u>0.3</u> mm	Reducer	$\phi$ <u>6.5</u>
Plug	<u>P4</u>	Fuel	<u>MSRF 25</u>
Muffler	<u>Ninja 2042</u>		

Diff. Oil	#	O-Ring	pcs.	Other
Front	<u>10000</u>	<u>0</u>	<input type="checkbox"/>	Other _____
Center	<u>7000</u>	<u>0</u>	<input type="checkbox"/>	Other _____
Rear	<u>3000</u>	<u>0</u>	<input type="checkbox"/>	Other _____

Tire	Front	Rear
Type	<u>Revolver M3</u>	Type <u>Revolver M3</u>
Foam	<u>White</u>	Foam <u>White</u>

Clutch	Clutch shoes	Aluminium
	<input checked="" type="checkbox"/>	_____
	<input type="checkbox"/>	Other _____
Spring	<u>1.0</u> mm	
Clutch bell / Spur gear	<u>14T / 48T</u>	

**Result**  
 Race time / Lap \_\_\_\_\_  
 Best lap (1Lap) \_\_\_\_\_

**Comments:**  
 \_\_\_\_\_  
 \_\_\_\_\_  
 \_\_\_\_\_  
 \_\_\_\_\_